

22 February 2013

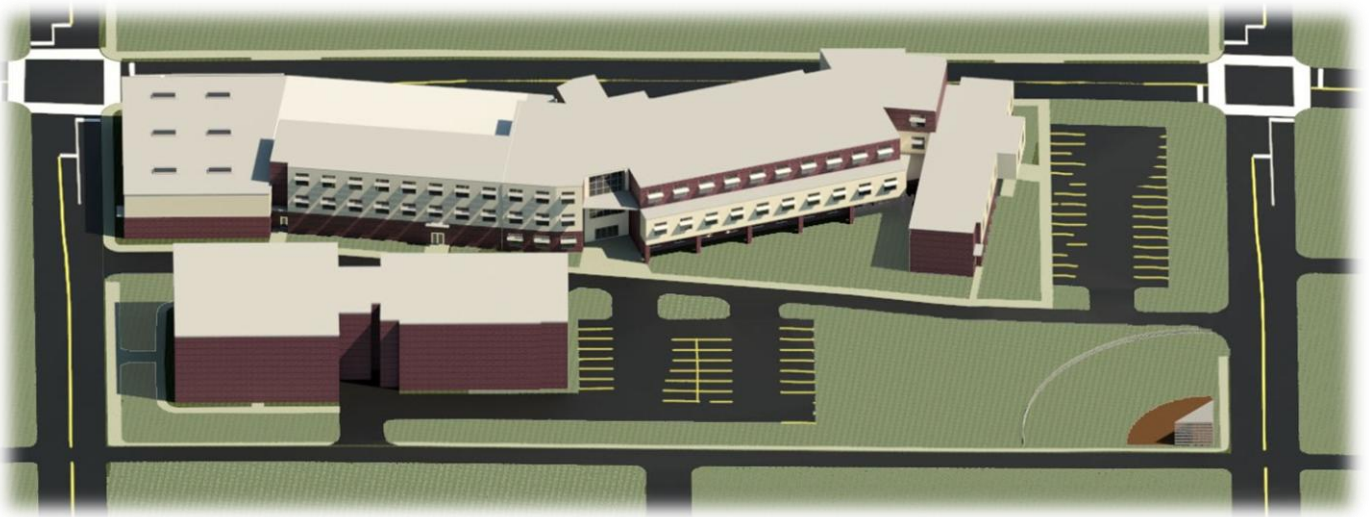

BUILDING INTEGRATION



Team Registration Number: 02-2013



The requirements of a typical elementary school, in conjunction with the socioeconomic conditions of the Reading school district, necessitated unique design decisions and innovative solutions. To achieve these solutions, a set of categories was created to define the purpose of each space in the school. It was determined that the three major functions of the building included user **Experience, Community, and Education** spaces. The function of these three categories dictated the integrated design of the various building systems, as well as the manner of dividing the building in terms of system types and discipline coordination. As such, these three sections will be the key areas of discussion and integration in the following content.

▼ Executive Summary	2
○ Introduction	2
○ BIM Execution Plan	2
○ Owners Goals	3
○ Nexus Goals	3
▼ Experience	4
○ Campus	4
○ Building Envelope	4
○ Building Envelope Rationale	5
○ Lobby	5
○ Lobby Rationale	6
▼ Community	7
○ Multipurpose Room	7
○ Multipurpose Room Rationale	7
○ Pool	8
○ Pool Rationale	8
▼ Education	10
○ Classroom	10
○ Classroom Rationale	11
▼ Sustainability / LEED	14
▼ Concluding Summarization	15
▼ Appendix	16
▼ Drawings	36

1. Executive Summary

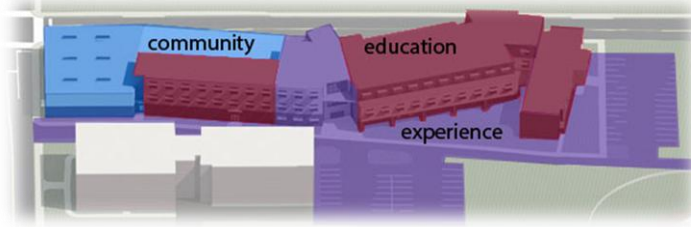

Figure 1: Building functions

1.1 Introduction

The experience aspect of Nexus' design encompasses the new campus layout, the façade, and main lobby. Through the creation of a new campus Nexus integrates safety with functionality; both of which need to be emphasized in the overarching design. The integration of insulated concrete form exterior bearing walls, exterior window louvers, with a brick and metal panel facade create a distinctive aesthetic appearance for the new elementary school. Lastly, an inviting three-story lobby will welcome students and community members into the school. This lobby acts as the "knuckle" of the building, bridging the community and education portions of the school. This too is a critical point for the building systems as different applications were implemented by all disciplines to adapt to the functionality of these very distinct spaces.

Community involvement is an integral aspect of Nexus' school design. The West end of the school contains a 24-hour health center, multi-purpose room, and a proposed second construction phase pool. These community areas are separate from the education portion of the building to ensure student safety and school security after hours. Moreover, this portion of the building is serviced by separate mechanical and electrical systems along with an enhanced structural system. The multi-purpose room also functions as a community shelter in the event of a natural disaster.

As it is the primary purpose of the school building, the educational portion is the most innovative part of Nexus' design. The main focus of this area was to create a learning environment that is augmented by the building systems. Designing to maximize efficient daylighting and increased ventilation ratios create an enhanced learning environment conducive to early childhood education. This open-air feel is heightened by exposed 14 foot ceiling with a lean structural system that allows for classroom flexibility. All of these aspects are integrated so the building itself will function as a learning tool.

1.2 BIM Execution Plan

The inception of this project involved the assimilation of the provided data and information regarding Reading school district. Nexus developed a "BIM Execution Plan" facilitate the integration of building systems. This execution plan specifically defines the roles to be fulfilled by the construction managers, structural, mechanical, and lighting/electrical engineers (see page 16 of Appendix). In creating the BIM Execution plan each design discipline created their own objectives to achieve the overall project goals. In addition, The BIM Execution Plan defines the information exchanges (softwares, models) between the four disciplines (see page 17 of Appendix). This enabled progress by recognizing the individual discipline decisions comprising the overall building design that were crucial to maintain advancement along the critical path design process.

Outlining objectives and goals was necessary to expedite each discipline's ability to work independently to create innovative solutions while seamlessly integrating these designs with the other disciplines. This prevented the team from having to perform unnecessary or additional work. Increasing the team's efficiency and effectiveness was critical throughout this project for each discipline to meet the several interim submissions scheduled by Nexus. Thus, the time spent in planning the early phases of this project facilitated productive team communication and progress. As a result, the interrelatedness of Nexus' building systems reduces redundancy and enhances the architecture of the school building (See Figure 2).

1.3 Owner Goals

safety & security



Safety is of utmost importance for the Reading School District. Having a sense of 'unseen' security will enhance the feeling of safety for the occupants. This too must address the possibility of incendiary events unfortunately becoming prevalent in today's society.

lifecycle & maintenance



Reading School District desires a building that can endure for 100 years. This building must be adaptable and flexible with new emerging technologies, learning styles, and teaching techniques. The flexibility of the spaces prolongs the building's lifecycle while the systems minimize the need for routine maintenance.

cost effective



Reading School District needs a building that is cost effective in both the short and long term. Being economically disadvantaged requires extra consideration to provide quantifiable value with monies spent. Nexus' building system and material selections alleviate first costs, while maintaining the integrity and affordability in the long run.

All of these goals are continually reiterated through the design of the Reading Elementary school. As such, it was decided that the following Mission Statement be Nexus' foundation for all design decisions.

Nexus' Mission Statement:

To develop a design that merges education with the community in a facility that is safe and cost effective while functioning as a learning tool.

1.4 Nexus Project Goals

Nexus' project goals were developed to achieve the owner goals and are supported by the individual discipline objectives.

integration



Integration is the all-encompassing goal of meeting the owner's objectives. As the main architectural components of the building were already established, Nexus focused on integrating the structural, mechanical, and lighting/electrical designs with the constructability of the building through predefined discipline goals and established information exchanges.

reduce, recover, reuse



This holistic building design was produced through lean practices. These lean practices were achieved by reducing, recovering, and reusing. These are reflected in all four design disciplines' decisions in order to save construction time, initial and lifecycle cost, as well as energy.

learning tool



Nexus desired to create a building that could be used as a learning tool for the end users. The building has exposed ceilings to allow users to understand the function of the exposed structural, mechanical, and electrical elements. All of these items were coordinated through extensive planning to meet the necessary discipline performance requirements.

2. Experience

2.1 Campus



In order to meet the owner’s objectives of safety and flexibility, Nexus deemed it necessary to reposition the building on the site. Prior to developing a learning environment, establishing site safety was imperative to all end-users. Reading has one of the worst crime rate statistics in Pennsylvania, so Nexus focused heavily on the importance of maintaining the safety and security of the students in the campus design¹. As seen in Figure 2, the main entrance was originally along a busy road. To improve campus security, Nexus turned the educational campus in on itself to shelter the students (see Figure 3).

This inward turn moved the main entrance from the north to the south facade creating a large group congregation space on the inside of the campus. This area allows students to congregate away from the main roads before and after school.

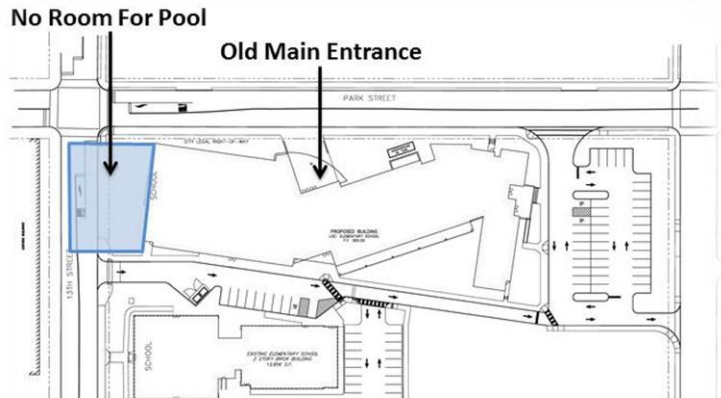

Figure 2: Original Site Plan Provided by the AEI Competition

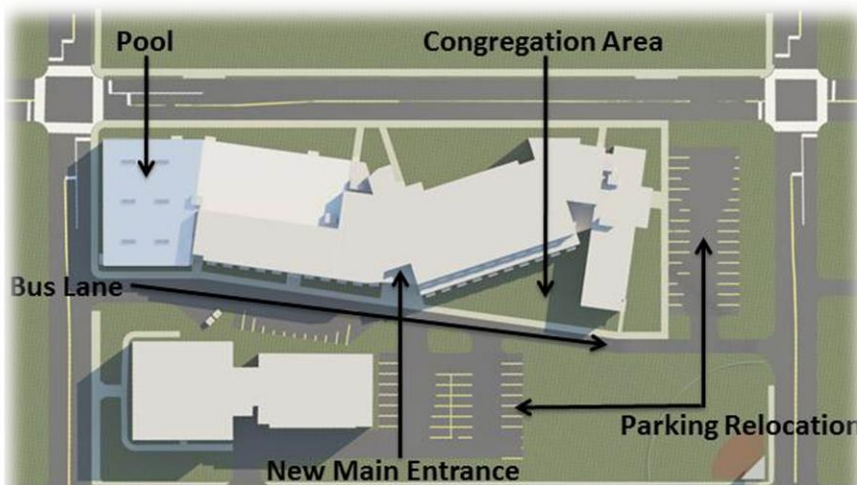

Figure 3: Nexus’ Revised Campus Plan (Building moved east, parking reallocated, and pool addition)

traffic of the temporary gravel road during the 15 month construction schedule (See page 20 of Appendix). There will also be automatic balusters implemented to prevent unwanted thoroughfare access during school hours.

2.2.1 Building Envelope



An integrated approach was taken when forming the façade of the building. Ultimately a brick on concrete bearing wall system was chosen. The concrete wall is made with Insulated Concrete Forms (ICFs). Insulated Concrete Forms are stay-in-place concrete forms that consist of two pieces of one-and-a-half-inch rigid insulation with six inches of reinforced concrete (as shown in Figure

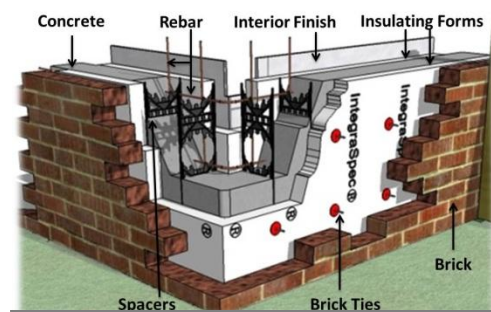

Figure 4: ICF Isometric Section: (www.integraspec.ie)

4). The exterior of the façade will be comprised mostly of brick with some colored aluminum panels. The interior of the façade will be finished with impact resistant gypsum wall board.

2.2.2 Building Envelope Rationale



The building envelope is a very integrated facet of the integrated design. All discipline performance criteria was taken into consideration to select an effective solution. From a construction management standpoint, ICFs are easily transportable and lightweight in addition to being easily erected. The ICFs also provide different structural purposes. They serve as bearing walls in the gravity structural system in addition to being shear walls for the lateral structural system.



Figure 5: Experience highlighted on first floor plan

A primary focus in designing the façade was ensuring it improved the energy efficiency of the building. The ICF's have an R-value of 24 which is more than double that of a typical façade system and greatly exceeds the minimum R-value of 19 recommended by ASHRAE for this region. Along with being a good thermal insulator, ICFs are also very airtight which improves energy efficiency by decreasing infiltration rates.

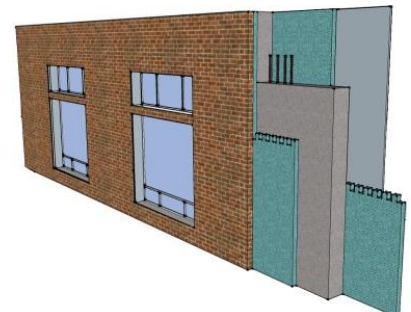

Figure 6: Isometric Section of Nexus ICF wall

One of the project goals was to provide plenty of daylight to the classroom spaces to promote an enjoyable learning environment. However, large windows are typically not possible in a concrete bearing wall system. In response to this, a window system was developed to provide enough daylight while maintaining the integrity of the gravity structural system. Seven foot wide windows with seven foot spacing were implemented into a 28-foot standard bay size. These windows fit seamlessly into the structural system so that only one beam falls over each window. Due to the ICF walls, the six inches of reinforced concrete is sufficient to carry the load from the beam. Also, the seven foot sizing and spacing create a repetitive pattern which is desirable for construction thus reducing cost through schedule savings. It should also be noted that there are minimal windows on the street level of the building except for the classrooms. These windows will utilize bullet resistant glazing to maximize student security by further preventing unwanted access to the school's interior.

In designing the roofing system for the school, it was decided that a white roof be implemented to reduce the "heat island effect." This also earns a LEED Credit for the building. It was decided that this roofing system be implemented in place of a green roof due to the increased cost associated with the additional structural and maintenance requirements. The savings as a result of this decision allowed for the reallocation of money to be spent on classrooms and other interior spaces.



- | | |
|--------------------------|--------------------------|
| 100 – Vestibule | 113 – Workroom |
| 101 – Lobby | 119 – Treating / Waiting |
| 108 – Principal's Office | 120 – Nurse Office |
| 109 – Clerical | 121 – Exam |
| 110 – Reception | 122 – Cots |
| 111 – Community Office | 123 – Toilet |
| 112 – Toilet | |

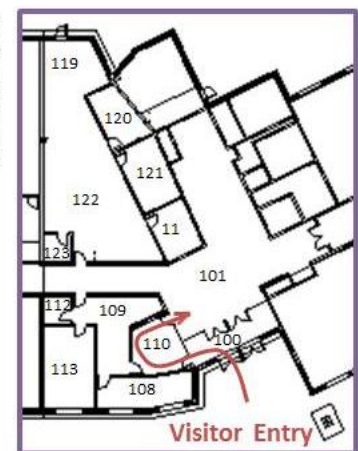

Figure 7: First Floor Plan with Enlarged Image of Redesigned

2.3.1 Lobby



Relocating the main entrance on the interior part of the site increases the

'unseen' sense of security. The theme of safety was carried into the building by maintaining one secure entrance as previously shown in Figure 4 above. The one entrance ensures that no unwanted visitors enter the facility, which is crucial at an elementary school with young children. This is the only secure point of entry into the building during school hours. All visitors must come in through the double doors and then turn left and check in at the front desk. This can be seen in Figure 7. There is also an entrance to the community side of the building that is accessible to the public during off hours to prevent visitors from entering the classroom wing. The addition of the atrium also created flexible learning space on the second and third floors that was not included in the original scope. This area can be seen behind the female in Figure 8. These spaces can be used as a reading nook or allow teachers to get their students out of the classroom and into a new more open space. These spaces are well lit thanks to the hanging pendants and the daylight that filters in through the curtain wall.



Figure 8: Second Floor Atrium/Lobby
Perspective Rendering

The lobby will also house the building monitoring hub which will track the energy use and savings of the building by housing the control system that works with both the lighting and mechanical system. This system will show occupants the real time energy use of the building and how the building's systems save energy. This too will act as a teaching tool for students so that they become aware of their own energy use.

2.3.2 Lobby Rationale



The cantilever over the entrance serves as an architectural element to welcome students into the building. It also serves the purpose of blocking direct solar heat gain during the summer. The atrium allows sunlight into the core of the building and further into the corridors. This reduces the amount of electric light needed during the day. At night, a combination of downlights and decorative pendants will be used to illuminate the space. (See page 31 of the Appendix for cutsheet.)

The lobby serves as the "knuckle" to the building because it is where both the structure and the mechanical system split. This is due to the vast differences in the structural and mechanical designs to meet varying the requirements of the adjacent community and education spaces. The lobby space will also be the only location in the building where acoustic ceiling tile is being utilized. This is to improve and reduce the reverberation time of this space. In determining the acoustical integrity of this space, it was assumed that a large amount of traffic would occur through this space periodically throughout the day. It was therefore decided to implement an acoustical drop ceiling to dampen to reduce the transmission of noise between the floors via the three-story atrium.

Lastly, the electrical lighting system will be tied into a single control system that works seamlessly with the mechanical system. This will automatically turn lights off in the lobby space when daylight is sufficient from the south-facing curtain wall.



Figure 9: Perspective Rendering of Main
Entrance on South Facade

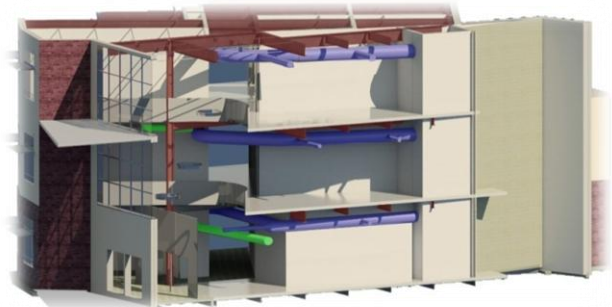

Figure 10: Building System

3. Community

3.1.1 Multipurpose Room – (Gym, Shelter, Cafeteria, Auditorium)



The multipurpose room is one of the most interesting spaces in the school as it is used in many different ways. During school, this space functions as the cafeteria for the students during lunch. One consequence of using the space as a cafeteria is the increased thermal load, which was addressed during the design of the mechanical system.

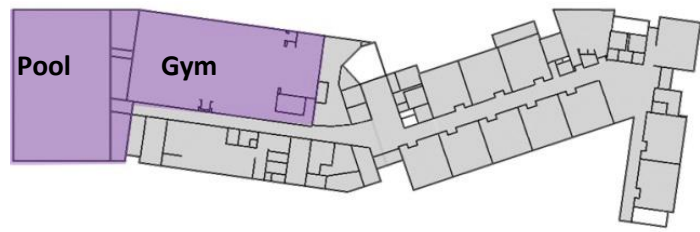

Figure 11: Community Wing Highlighted on First Floor Plan

Another obvious purpose for the room is its use as a gymnasium for classes and after-school sporting events (Figure 12). The depth of the roof joists was limited to 40 inches, and the mechanical ducts are nestled between the walls and the joists so that they do not interfere with such events. The design for the multipurpose space also includes a stage for performances. Therefore the acoustical design of the space was another design factor. To improve the acoustic quality of the space, slotted concrete masonry unit walls and acoustical roof deck will be used. Since the performances in the space will call for versatility in the lighting system, the space uses compact fluorescent lamps that have a short restrike time. (See page 32 in Appendix for cutsheet.) This way, the lighting in the space can be adjusted easily depending on how the room is used. The multipurpose room also acts as an emergency shelter. One of the requirements of the shelter is that it cannot include windows in the event of potential projectiles. The room also requires strong exterior walls, which are adequately provided by the exterior ICF walls.



Figure 12: The multipurpose room can be used for stage performances or basketball games

The multipurpose room is truly a centerpiece of the Nexus triangle of community, experience, and education. It provides members of the community with a place to play pick-up basketball games in the evenings and a safe place to go during emergency situations. It also gives students and parents a place to experience school plays and band performances while also providing increased opportunities for physical health and education.

3.1.2 Multipurpose Room Rationale



Providing value to the community was one of Nexus' key objectives in designing this building. The multipurpose room is designed to be used in a number of different ways for both students and the community. The implementation of 40 inch roof joists provides space for mechanical ductwork. As this space is also an emergency shelter, the roof structure of the building must be heavy enough to resist uplift during wind storms. Therefore, the same slab and deck system used for the floors elsewhere in the building is used to achieve the required mass (Figure 13).

Another difficult decision involved the exclusion of windows from the space. It was determined that the safest and most cost-effective solution for protecting against projectiles would be to exclude windows and skylights from the design. This decision made the need for a flexible lighting system even greater. For this reason a fluorescent lighting system was chosen for the room. Although designing this space as an emergency shelter introduced added costs, these costs will be minimal and will provide value to the community. This too will meet the project goals of increasing safety and security of not just the students but the community as well.



Figure 13: Aerial Section of Multipurpose Room

3.2.1 Pool



Figure 14: View of pool from balcony

The swimming pool functions as a direct link to the community. The pool is six lanes wide and will be used primarily for recreational purposes (Figure 14). The trusses in this space are similar to the gym, however they are 5' deep and spaced 8.5' apart. This allows for the mechanical ductwork to run directly through the trusses. The conditioned air will be supplied along the perimeter of the pool enclosure. As per ASHRAE HVAC Applications, the pool water will be heated to 80°F and the air temperature will be conditioned to approximately 82°F. This space has a peak heating load of approximately 350 MBh (see page 29 of Appendix).

There is one large window on the north side of the pool enclosure. This will allow daylight to penetrate the space while not allowing direct glare. Six skylights will be constructed in the ceiling to provide additional daylight. The lighting fixtures will be wall-mounted and placed along the perimeter of the entire enclosure. (See page 33 of Appendix for cutsheet.)

3.2.2 Pool Rationale



The pool is being designed as an add-alternate should the school district want to build it at a later date due to funding restrictions (see Construction Report for further explanation). If the school board chooses not to move forward with constructing the pool, the extra \$2,012,588 could be allocated at the school board's discretion. However, if the pool is constructed in a second phase, the cost of the pool would rise to \$2,683,654 (a 33% increase) for general conditions costs (overhead, remobilization, site constraints, etc.) (See page 18 of Appendix for a detailed cost estimate breakdown).

A major decision that had to be made early on was the design of the windows for this space. Concerns included the possibility of direct glare in swimmers eyes and also the heat loss that would occur through the glazing.

Pool Phase 1	
SF	8,925
\$/SF	\$ 225.50
Total Cost	\$2,012,588
Pool Phase 2	
SF	8,925
\$/SF	\$ 300.69
Total Cost	\$2,683,654
Variance	
	\$ 671,067

Figure 16: Pool Cost Comparisons

Therefore, one large window on the north wall was deemed the best solution as shown in Figure 15. This window will allow daylight to penetrate the space with no direct glare. The glass chosen has a low U-value of 0.28 and solar heat gain coefficient of 0.23. Additional daylight is brought to the space with skylights that will be constructed using diffuse glass to again ensure no direct glare will affect the swimmer's experience (Figure 16). Wall-mounted metal halide upright fixtures will be used to illuminate the space indirectly to reduce the amount of glare on the surface of the pool.



Figure 15: Interior pool perspective rendering

The ductwork layout was designed to keep continuous airflow over the window and perimeter to prevent condensation. This will also prevent drafts from directly hitting the swimmers in the pool, as this creates user discomfort. Another concern of the mechanical design was the chemicals used to treat the pool water. The evaporated tri-chloramines from the pool water can cause air quality problems that link to eye, nose, and throat irritation². The exhaust system is located directly over the pool to prevent occupant discomfort through the immediate elimination of these vapors. These chemicals are also corrosive to the building system and equipment. Protective coatings will be applied to the necessary structure and mechanical systems to ensure the removal of these vapors while protecting the integrity and longevity of the systems. Mechanical system too was designed so that the pool could be incorporated at a later date. Should the pool not be built with the rest of the project, the energy efficiency of the mechanical system would decrease slightly due to the reduction in heat recovery.

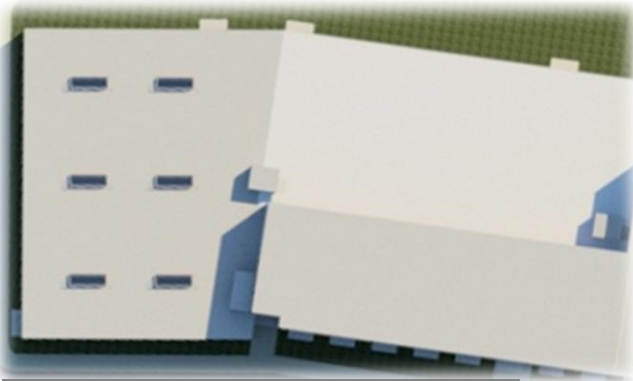

Figure 16: Aerial view of pool skylight layout

The lighting scheme was designed with operation and maintenance in mind. No fixtures were placed over the pool surface; there are wall-mounted fixtures lining the perimeter. This will allow for ease of maintenance because no bulbs will need to be changed over the water surface. The pool was also one of the spaces all disciplines that make up Nexus worked together the most. As previously mentioned, the window design impacted both the lighting and the mechanical systems. The truss structure was sized with the ductwork in mind. The openings in the trusses are large enough for the mechanical ductwork to run through unencumbered.

This area left blank for more text on Community (gym/pool)

4. Education

4.1 Classroom



With education understandably being the most important component of the building, this became the key area of focus in integrating systems to provide an optimized learning environment. This area also presented most of the building's challenges. To ensure the building acts as a learning tool, the decision was made to expose discipline systems in the classrooms to facilitate an understanding of how the building works. This alone presented many challenges in maintaining a practical functionality of the classrooms and balancing system efficiency with architectural aesthetics. To achieve this, Nexus took the approach of reducing the application of unnecessary materials, such as ceiling tiles.



Figure 17: Student Classroom Perspective Rendering

As is visible in Figure 17, by exposing the ceiling in the classroom, the 14' ceiling height creates a large open feeling. As previously mentioned students will be able to see the color-coded systems that comprise the space, starting with the 20" deep structural steel members that support the acoustic metal decking for the floor above.



Figure 18: Teacher Classroom Perspective Rendering

that they may be turned down or even off when this side of the facility is not being used.

An additional aspect of increasing the quality of this environment was to bring natural light into the space. Studies show that daylighting is an intrinsic part of improving overall learning capabilities of students³. Increased daylighting too, will save money by reducing electrical lighting costs. Special considerations were made in the functionality of each window to allow for optimized solar penetration at each façade. The

Additionally the students will be able to see the exposed ductwork conditioning the space (Figure 18). The space will utilize a 100% outdoor air system as studies by the Environmental Protection Agency have shown that increased ventilation rates improve teacher and student performance. Through use of this system we are able to decrease the size of the ductwork which allows for a more compact design. The duct is housed within a lateral chase running along the hallways. One supply outdoor air handler will be coupled with one exhaust outdoor air handler so

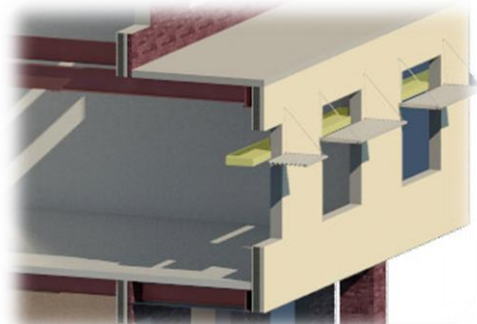

Figure 19: Close-up of Windows with Solar Shading

south facing windows are designed with both an exterior overhang and an interior light shelf as is shown in Figure 19. The exterior overhang (attached with bolts anchored into the ICFs after the brick or metal panels are installed) will prevent direct penetration into the classroom during the summer. The interior light shelf (constructed of metal studs and gypsum wall board) will reflect the solar rays up and into the space so that it is lit with ambient daylighting. The classrooms will also have manual shades that the teacher can use to control the amount of daylight. The primary lighting sources are the two rows of direct-indirect T5 pendants. (See page 34 of Appendix for cutsheet.) The second electrical lighting source is a wall-mounted fixture that runs along the top of the black board to provide more task-specific lighting. Vacancy sensors and dimmers will be installed to save energy in the classrooms.

4.2 Classroom Rationale



As with the other aspects of our building design we first looked into initial costs and potential savings that could be made from the original drawings. It was determined that a method of pseudo-modularization be developed to decrease construction schedule as well as the associated labor costs. The reasoning for this decision was based on the redundancy and continuity of each classroom on this side of the building. It made sense to standardize these rooms in a method of facilitating and expediting the construction process as all of these spaces will require the same design considerations. To achieve this, the first unique component was the redesign of the structural system. The original building design called for two rows of interior columns that lined the internal corridor as is shown in Figure 21.

It was determined that one of these column lines be eliminated to create a standard bay size and an axis of symmetry along the column line as is shown in Figure 22. This standardization of the structural grid (see page 25 of Appendix) will greatly expedite the manufacturing and construction process while reducing the possibility of errors. Additionally, the building requires lateral support for the seismic loads that may act on the building (see pages 21-22 of Appendix). In order to provide adequate lateral resistance while maintaining sufficient space for the mechanical systems, the building lateral system consists of A-frame steel concentric braces designed in



Figure 20: Education Wing Highlighted on Building Floor Plan with Structural Bay Redesign Called out in Red

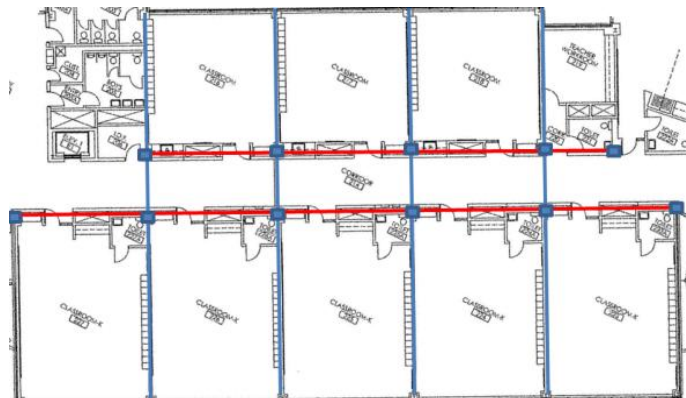

Figure 21: Original Structural Configuration

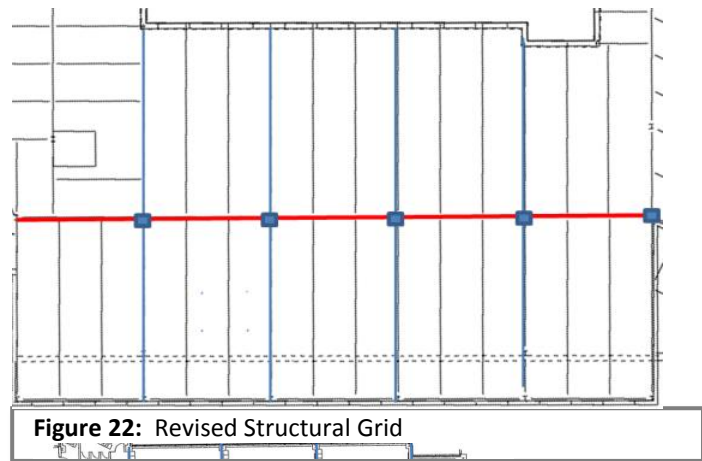

Figure 22: Revised Structural Grid

accordance with the member forces determined through ETABS modeling of the seismic loads (see pages 23-24 of Appendix).

In order to achieve standardization of the structural grid, several other components had to be taken into account with regard to other disciplines. Although the original structural grid configuration had more columns, connections, and footings (ultimately driving up initial cost and construction time), this initial configuration provided a large plenum space to run the necessary ductwork and piping along the corridors. As such, in continuation of the modularization, lateral mechanical chases were developed to run the supply and exhaust ductwork for the 100% outside air mechanical system. These chases run on either side of the corridor and allow for continuous duct runs along the length of this part of the building as is shown in Figure 23.

In addition to lateral chases throughout the corridors, vertical chases were utilized in two places in the building, one in the central corridor and one in the east corridor of the education wing. These will house the large duct runs directly from the outdoor air units as well as the piping for the Ethylene-Glycol run around system. This piping will connect all outdoor air units, exhaust air units, and the hydronic unit in the basement (see page 26 of Appendix). The basement mechanical room will also house all other mechanical equipment including 3 chillers, pumps, and the boiler (see page 27 of Appendix).

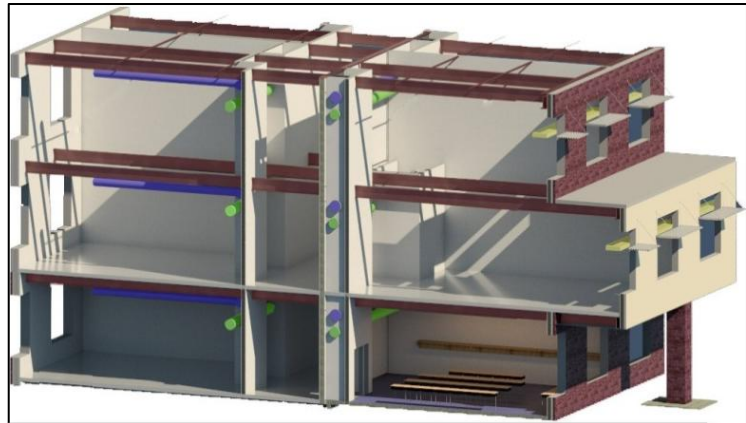

Figure 23: Building Section showing Mechanical System running along hallway in lateral chase

As can be seen in the Figure 24, the mechanical system will utilize round duct work. Round duct work is actually cheaper to make and install because it can be fabricated directly to the correct size and length at the manufacturing facility. This will allow for savings in initial construction costs. Additionally, round duct provides more of an aesthetic finish than that of utilitarian rectangular applications. Because of this, it was decided to expose these round ducts in certain areas of the lateral chase to increase the design goal of making the building a learning tool. This too will save on costs of building a bulkhead to house this lateral chase along the span of the corridor.

This area left blank for more text on Education

This page left blank for more text on Education

We are also still determining how to incorporate our References into the text. We list them here just for reference. Most likely, they will be in a footer (instead of wasting a page of the Appendix on them)

1. <http://www.portal.state.pa.us/portal/server.pt/community/statistics/5393/crime_statistics/494652>

2. <<http://erj.ersjournals.com/content/29/4/690.full>>

3.

<http://architecture.mit.edu/house_n/web/resources/articles/education/Boston%20Globe%20Online%20-%20Nation%20%20World%20-%20Study%20says%20natural%20light%20boosts%20learning.htm>

5. Sustainability / LEED

LEED 2009 for Schools New Construction and Major Renovations		Project Name	
Project Checklist		Date	
Sustainable Sites Possible Points: 24		Materials and Resources, Continued	
<input checked="" type="checkbox"/> Y	Prereq 1 Construction Activity Pollution Prevention	<input checked="" type="checkbox"/> Y Credit 3 Materials Reuse 1 to 2	
<input checked="" type="checkbox"/> Y	Prereq 2 Environmental Site Assessment	<input checked="" type="checkbox"/> Y Credit 4 Recycled Content 1 to 2	
<input checked="" type="checkbox"/> Y	Credit 1 Site Selection 1	<input checked="" type="checkbox"/> Y Credit 5 Regional Materials 1 to 2	
<input checked="" type="checkbox"/> Y	Credit 2 Development Density and Community Connectivity 4	<input checked="" type="checkbox"/> Y Credit 6 Rapidly Renewable Materials 1	
<input checked="" type="checkbox"/> Y	Credit 3 Brownfield Redevelopment 1	<input checked="" type="checkbox"/> Y Credit 7 Certified Wood 1	
<input checked="" type="checkbox"/> Y	Credit 4.1 Alternative Transportation—Public Transportation Access 4	Indoor Environmental Quality Possible Points: 19	
<input checked="" type="checkbox"/> Y	Credit 4.2 Alternative Transportation—Bicycle Storage and Changing Rooms 1	<input checked="" type="checkbox"/> Y Prereq 1 Minimum Indoor Air Quality Performance	
<input checked="" type="checkbox"/> Y	Credit 4.3 Alternative Transportation—Low-Emitting and Fuel-Efficient Vehicles 2	<input checked="" type="checkbox"/> Y Prereq 2 Environmental Tobacco Smoke (ETS) Control	
<input checked="" type="checkbox"/> Y	Credit 4.4 Alternative Transportation—Parking Capacity 2	<input checked="" type="checkbox"/> Y Prereq 3 Minimum Acoustical Performance	
<input checked="" type="checkbox"/> Y	Credit 5.1 Site Development—Protect or Restore Habitat 1	<input checked="" type="checkbox"/> Y Credit 1 Outdoor Air Delivery Monitoring 1	
<input checked="" type="checkbox"/> Y	Credit 5.2 Site Development—Maximize Open Space 1	<input checked="" type="checkbox"/> Y Credit 2 Increased Ventilation 1	
<input checked="" type="checkbox"/> Y	Credit 6.1 Stormwater Design—Quantity Control 1	<input checked="" type="checkbox"/> Y Credit 3.1 Construction IAQ Management Plan—During Construction 1	
<input checked="" type="checkbox"/> Y	Credit 6.2 Stormwater Design—Quality Control 1	<input checked="" type="checkbox"/> Y Credit 3.2 Construction IAQ Management Plan—Before Occupancy 1	
<input checked="" type="checkbox"/> Y	Credit 7.1 Heat Island Effect—Non-roof 1	<input checked="" type="checkbox"/> Y Credit 4 Low-Emitting Materials 1 to 4	
<input checked="" type="checkbox"/> Y	Credit 7.2 Heat Island Effect—Roof 1	<input checked="" type="checkbox"/> Y Credit 5 Indoor Chemical and Pollutant Source Control 1	
<input checked="" type="checkbox"/> Y	Credit 8 Light Pollution Reduction 1	<input checked="" type="checkbox"/> Y Credit 6.1 Controllability of Systems—Lighting 1	
<input checked="" type="checkbox"/> Y	Credit 9 Site Master Plan 1	<input checked="" type="checkbox"/> Y Credit 6.2 Controllability of Systems—Thermal Comfort 1	
<input checked="" type="checkbox"/> Y	Credit 10 Joint Use of Facilities 1	<input checked="" type="checkbox"/> Y Credit 7.1 Thermal Comfort—Design 1	
Water Efficiency Possible Points: 11		<input checked="" type="checkbox"/> Y Credit 7.2 Thermal Comfort—Verification 1	
<input checked="" type="checkbox"/> Y	Prereq 1 Water Use Reduction—20% Reduction	<input checked="" type="checkbox"/> Y Credit 8.1 Daylight and Views—Daylight 1 to 3	
<input checked="" type="checkbox"/> Y	Credit 1 Water Efficient Landscaping 2 to 4	<input checked="" type="checkbox"/> Y Credit 8.2 Daylight and Views—Views 1	
<input checked="" type="checkbox"/> Y	Credit 2 Innovative Wastewater Technologies 2	<input checked="" type="checkbox"/> Y Credit 9 Enhanced Acoustical Performance 1	
<input checked="" type="checkbox"/> Y	Credit 3 Water Use Reduction 2 to 4	<input checked="" type="checkbox"/> Y Credit 10 Mold Prevention 1	
<input checked="" type="checkbox"/> Y	Credit 3 Process Water Use Reduction 1	Innovation and Design Process Possible Points: 6	
Energy and Atmosphere Possible Points: 33		<input checked="" type="checkbox"/> Y Credit 1.1 Innovation in Design: Specific Title 1	
<input checked="" type="checkbox"/> Y	Prereq 1 Fundamental Commissioning of Building Energy Systems	<input checked="" type="checkbox"/> Y Credit 1.2 Innovation in Design: Specific Title 1	
<input checked="" type="checkbox"/> Y	Prereq 2 Minimum Energy Performance	<input checked="" type="checkbox"/> Y Credit 1.3 Innovation in Design: Specific Title 1	
<input checked="" type="checkbox"/> Y	Prereq 3 Fundamental Refrigerant Management	<input checked="" type="checkbox"/> Y Credit 1.4 Innovation in Design: Specific Title 1	
<input checked="" type="checkbox"/> Y	Credit 1 Optimize Energy Performance 1 to 19	<input checked="" type="checkbox"/> Y Credit 2 LEED Accredited Professional 1	
<input checked="" type="checkbox"/> Y	Credit 2 On-Site Renewable Energy 1 to 7	<input checked="" type="checkbox"/> Y Credit 3 The School as a Teaching Tool 1	
<input checked="" type="checkbox"/> Y	Credit 3 Enhanced Commissioning 2	Regional Priority Credits Possible Points: 4	
<input checked="" type="checkbox"/> Y	Credit 4 Enhanced Refrigerant Management 1	<input checked="" type="checkbox"/> Y Credit 1.1 Regional Priority: Specific Credit 1	
<input checked="" type="checkbox"/> Y	Credit 5 Measurement and Verification 2	<input checked="" type="checkbox"/> Y Credit 1.2 Regional Priority: Specific Credit 1	
<input checked="" type="checkbox"/> Y	Credit 6 Green Power 2	<input checked="" type="checkbox"/> Y Credit 1.3 Regional Priority: Specific Credit 1	
Materials and Resources Possible Points: 13		<input checked="" type="checkbox"/> Y Credit 1.4 Regional Priority: Specific Credit 1	
<input checked="" type="checkbox"/> Y	Prereq 1 Storage and Collection of Recyclables	Total Possible Points: 110	
<input checked="" type="checkbox"/> Y	Credit 1.1 Building Reuse—Maintain Existing Walls, Floors, and Roof 1 to 2	Certified 40 to 49 points Silver 50 to 59 points Gold 60 to 79 points Platinum 80 to 110	
<input checked="" type="checkbox"/> Y	Credit 1.2 Building Reuse—Maintain 50% of Interior Non-Structural Elements 1		
<input checked="" type="checkbox"/> Y	Credit 2 Construction Waste Management 1 to 2		

Figure 24: LEED Checklist

It is believed that this building, in our inclusion of many sustainable and cost effective methods due to the integrated design of Team Nexus will be able to achieve a minimum of LEED Silver Certification. It is a goal to push the building performance and material selection to a degree of achieving LEED Silver. This will provide the school with a \$542,850 credit that will help to offset the overall building construction costs (see PlanCon calculations in Construction Report). Achieving LEED certification helps meet the district's objective of lifecycle savings. Nexus took the approach of focusing on the learning environment in order to meet this requirement. An excellent example of this is the mechanical system. In order to create a comfortable learning environment the mechanical system had to be sized to improve indoor air quality by increasing the amount of outside air provided. The motive for this was improving the learning environment but it in turn also helped us meet LEED requirements under the indoor environmental quality category. The learning environment mentality also applies to the water efficiency, energy and atmosphere, materials and resources, and sustainable site categories. Additionally the mechanical system will have a heat recovery efficiency of approximately 65% percent while the facility is in use during the academic school year (see page 28 of Appendix). This provides tremendous savings to the school district (see page 30 of Appendix). If the school were to be in full use year round the mechanical system would still be able to reduce energy costs associated with the building loads by about 50% (see page 29 of Appendix). See Figure 24 LEED Checklist. In total, the decisions made in the integrated design process facilitate an improved learning environment while practicing sustainable methods that will ultimately improve the quality experienced by the occupants.

6. Concluding Summarization

In conclusion, Nexus believes it has met Reading School District’s owner objectives through the support of the project and discipline specific goals. The goals set forth by Nexus were created in order to deliver a building that satisfies the needs of the students, teachers, and community members. Nexus is confident that the proposed elementary school successfully achieves and exceeds the district’s objectives (Figure 25). The Reading Elementary school contains a plethora of examples of innovative design solutions through each of the integrated disciplines working on the project.

The distinguishing figure below represents the union of the experience, community, and education portions of the school building. Each building section operates amongst itself to service a distinctive function while also supporting its two other building section counterparts. The experience portion welcomes all individuals onto the campus and creates a sense of security. This leads people to the community portion of the school where essential needs are met for the local area. Most importantly, the educational portion of the school is bolstered by the efficient building systems and support areas, while serving as the foundation of each individual student’s first learning endeavor, developing them into productive community members.

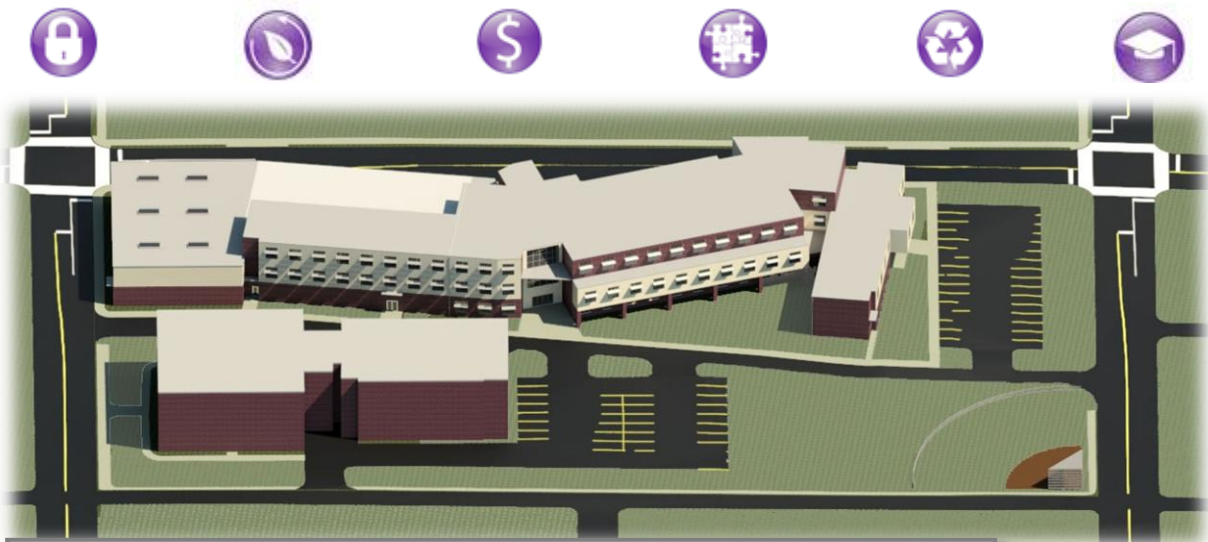
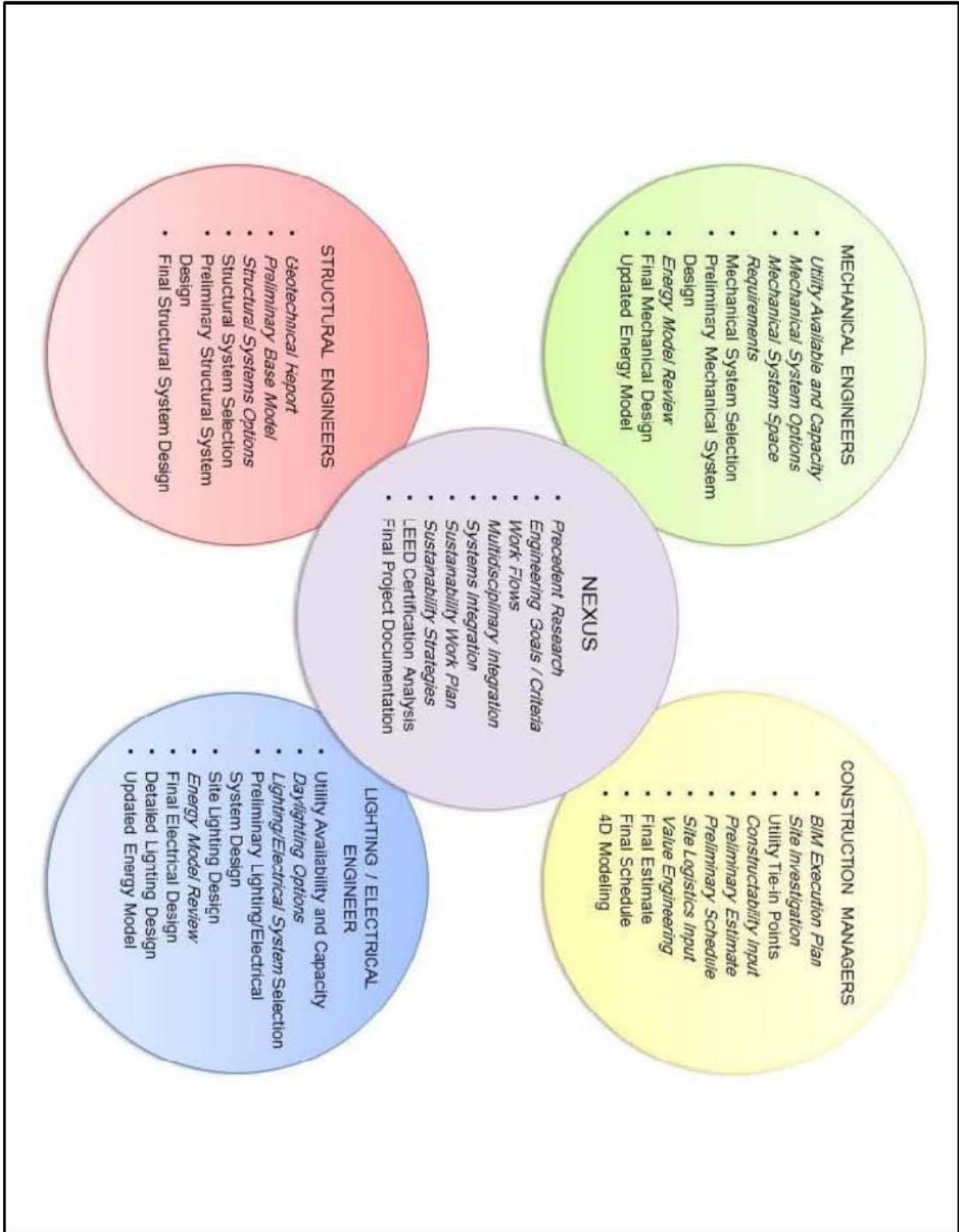

Figure 25: Aerial Rendering of Nexus’ New Reading School District Elementary School



Nexus Discipline Roles and Responsibilities



Nexus Software Information Exchanges

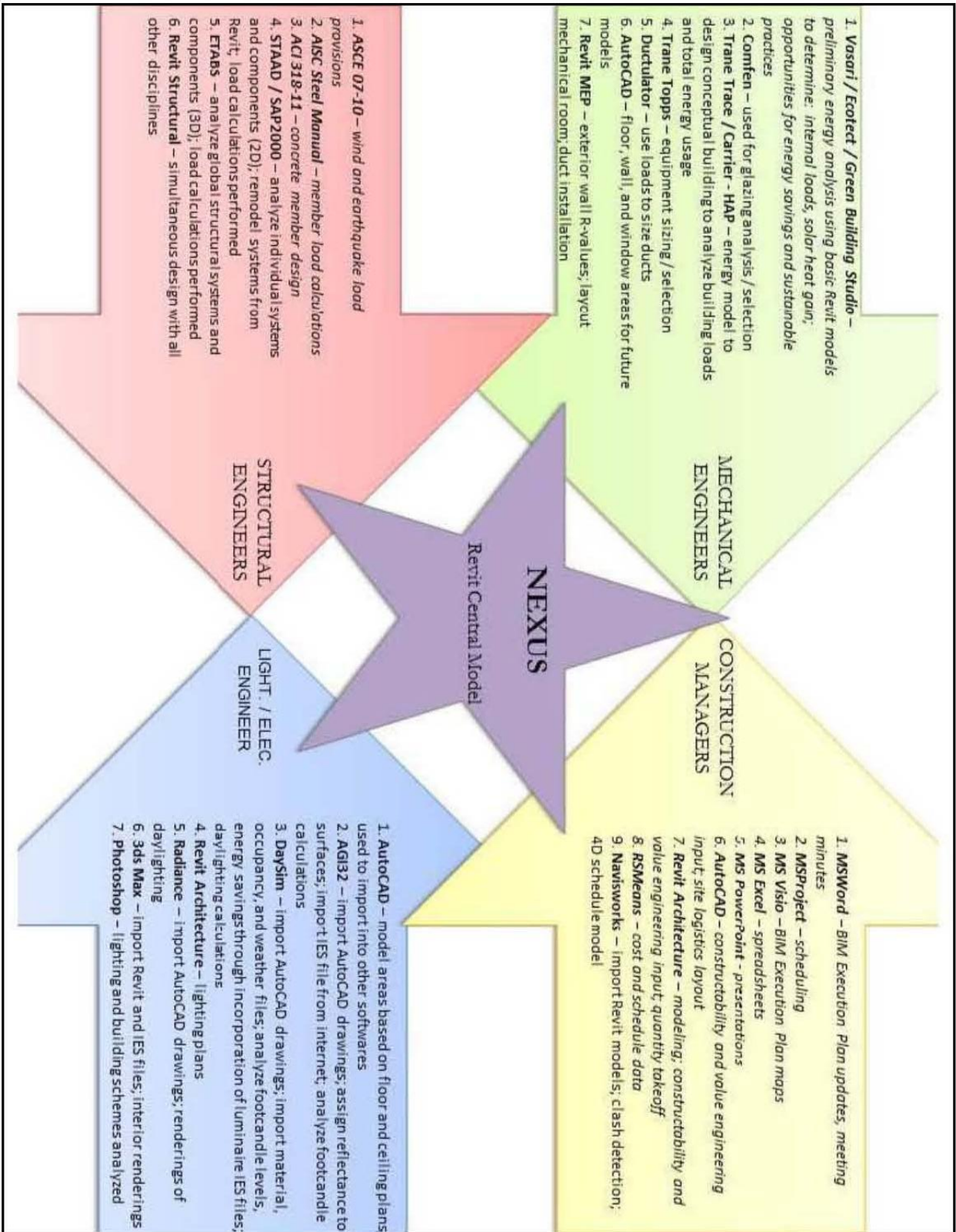

UNIFORMAT COST ESTIMATE

Uniformat Cost Estimate					
A. Substructure	\$ 713,750	A10 Foundations	\$ 459,750	A1010 Standard Foundations	\$ 138,500
				A1020 Special Foundations	\$ 200,000
				A1030 Slab on Grade	\$ 121,250
		A20 Basement Construction	\$ 254,000	A2010 Basement Excavation	\$ 150,000
				A2020 Basement Walls	\$ 104,000
B. Shell	\$ 6,390,250	B10 Superstructure	\$ 1,777,250	B1010 Floor Construction	\$ 1,381,000
				B1020 Roof Construction	\$ 396,250
		B20 Exterior Enclosures	\$ 3,908,000	B2010 Exterior Walls	\$ 3,239,000
				B2020 Exterior Windows	\$ 629,000
				B2030 Exterior Doors	\$ 40,000
		B30 Roofing	\$ 705,000	B3010 Roof Coverings	\$ 700,000
				B3020 Roof Openings	\$ 5,000
C. Interiors	\$ 1,970,000	C10 Interior Construction	\$ 965,000	C1010 Partitions	\$ 830,000
				C1020 Interior Doors	\$ 75,000
				C1030 Fittings	\$ 60,000
		C20 Stairs	\$ 110,000	C2010 Stair Construction	\$ 103,000
				C2020 Stair Finishes	\$ 7,000
		C30 Interior Finishes	\$ 895,000	C3010 Wall Finishes	\$ 180,000
				C3020 Floor Finishes	\$ 500,000
				C3030 Ceiling Finishes	\$ 215,000
D. Services	\$ 6,475,000	D10 Conveying	\$ 175,000	D1010 Elevators & Lifts	\$ 175,000
				D1020 Escalators & Moving Walks	\$ -
				D1090 Other Conveying Systems	\$ -
		D20 Plumbing	\$ 1,400,000	D2010 Plumbing Fixtures	\$ 100,000
				D2020 Domestic Water Distribution	\$ 300,000
				D2030 Sanitary Waste	\$ 240,000
				D2040 Rain Water Drainage	\$ 74,000
				D2090 Other Plumbing Systems	\$ 686,000
		D30 HVAC	\$ 2,800,000	D3010 Energy Supply	\$ -
				D3020 Heat Generating Systems	\$ 140,000
				D3030 Cooling Generating Systems	\$ 280,000
				D3040 Distribution Systems	\$ 520,000
				D3050 Terminal & Package Units	\$ 840,000
				D3060 Controls & Instrumentation	\$ 360,000
				D3070 Systems Testing & Balancing	\$ 200,000
				D3090 Other HVAC Systems & Equipment	\$ 460,000
		D40 Fire Protection	\$ 175,000	D4010 Sprinklers	\$ 105,000
				D4020 Standpipes	\$ 62,000
				D4030 Fire Protection Specialties	\$ 8,000
				D4090 Other Fire Protection Systems	\$ -
		D50 Electrical	\$ 1,925,000	D5010 Electrical Service & Distribution	\$ 551,250
				D5020 Lighting and Branch Wiring	\$ 1,023,750
				D5030 Communications & Security	\$ 350,000
				D5090 Other Electrical Systems	\$ -
E. Equipment & Furnishings	\$ 300,000	E10 Equipment	\$ -	E1010 Commercial Equipment	\$ -
				E1020 Institutional Equipment	\$ -
				E1030 Vehicular Equipment	\$ -
				E1090 Other Equipment	\$ -
		E20 Furnishings	\$ 300,000	E2010 Fixed Furnishings	\$ 200,000
				E2020 Movable Furnishings	\$ 100,000
F. Special Construction & Demolition	\$ -	F10 Special Construction	\$ -	F1010 Special Structures	\$ -
				F1020 Integrated Construction	\$ -
				F1030 Special Construction Systems	\$ -
				F1040 Special Facilities	\$ -
				F1050 Special Controls and Instrumentation	\$ -
		F20 Selective Building Demolition	\$ -	F2010 Building Elements Demolition	\$ -
				F2020 Hazardous Components Abatement	\$ -
G. Building Sitework	\$ 601,000	G10 Site Preparation	\$ 175,000	G1010 Site Clearing	\$ -
				G1020 Site Demolition and Relocations	\$ -
				G1030 Site Earthwork	\$ 125,000
				G1040 Hazardous Waste Remediation	\$ 50,000
		G20 Site Improvements	\$ 301,000	G2010 Roadways	\$ 127,500
				G2020 Parking Lots	\$ 133,500
				G2030 Pedestrian Paving	\$ 15,000
				G2040 Site Development	\$ -
				G2050 Landscaping	\$ 25,000
		G30 Site Mechanical Utilities	\$ 75,000	G3010 Water Supply	\$ 13,000
				G3020 Sanitary Sewer	\$ 15,000
				G3030 Storm Sewer	\$ 16,000
				G3040 Heating Distribution	\$ 12,000
				G3050 Cooling Distribution	\$ 8,000
				G3060 Fuel Distribution	\$ 11,000
				G3090 Other Site Mechanical Utilities	\$ -
		G40 Site Electrical Utilities	\$ 50,000	G4010 Electrical Distribution	\$ 10,000
				G4020 Site Lighting	\$ 25,000
				G4030 Site Communications & Security	\$ 15,000
				G4090 Other Site Electrical Utilities	\$ -
		G90 Other Site Construction	\$ -	G9010 Service and Pedestrian Tunnels	\$ -
				G9090 Other Site Systems & Equipment	\$ -
Z. General Conditions	\$ 1,385,545	Z10 Design Allowance	\$ -		
		Z20 Overhead & Profit	\$ 1,385,545	Z2010 Overhead	\$ 1,072,995
				Z2020 Profit	\$ 312,550
TOTAL	\$ 17,835,545				

DESIGN, PRECONSTRUCTION, AND CONSTRUCTION MILESTONE SCHEDULE

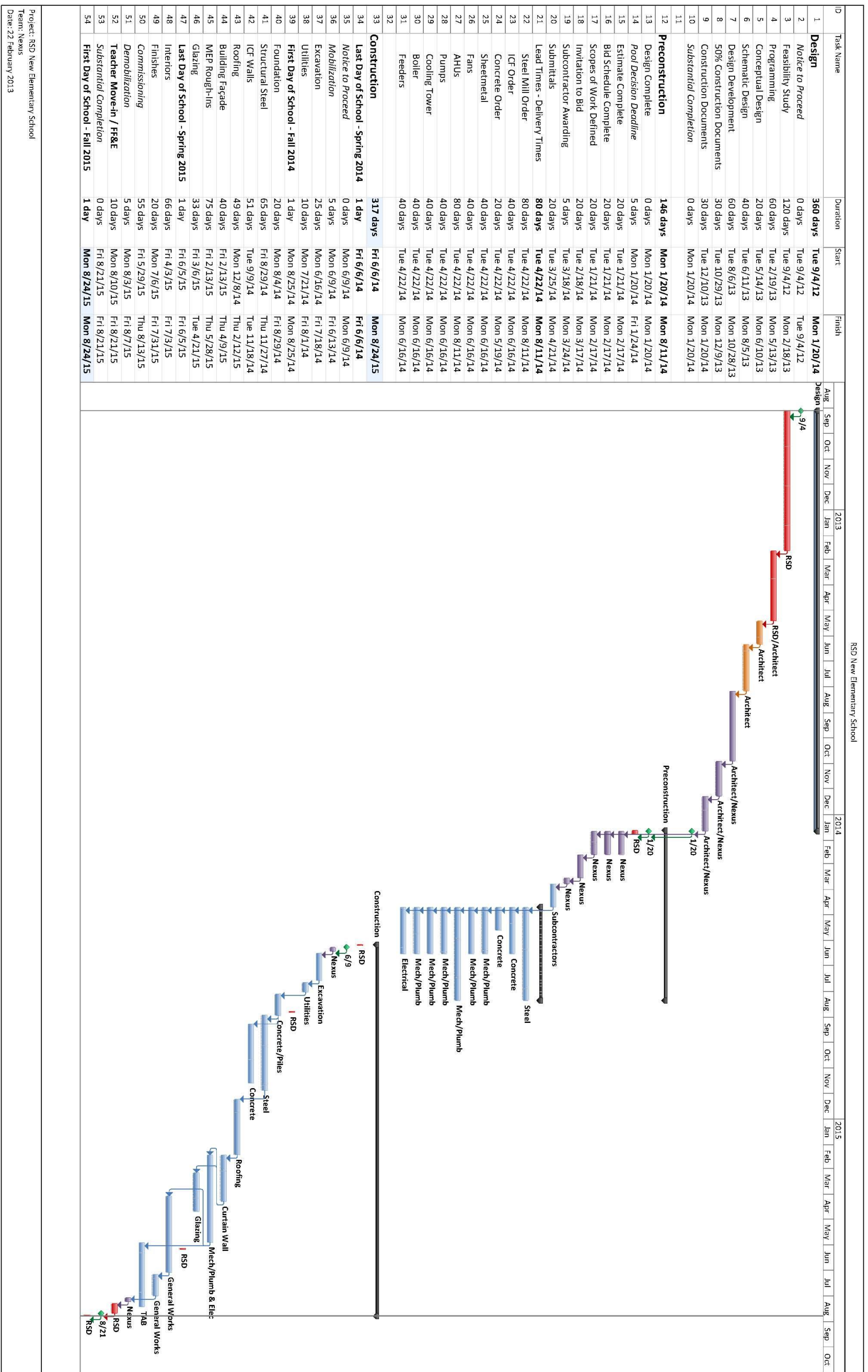

Project: RSD New Elementary School
 Team: Nexus
 Date: 22 February 2013

RSD New Elementary School

NAVISWORKS 4D MODEL SEQUENCE

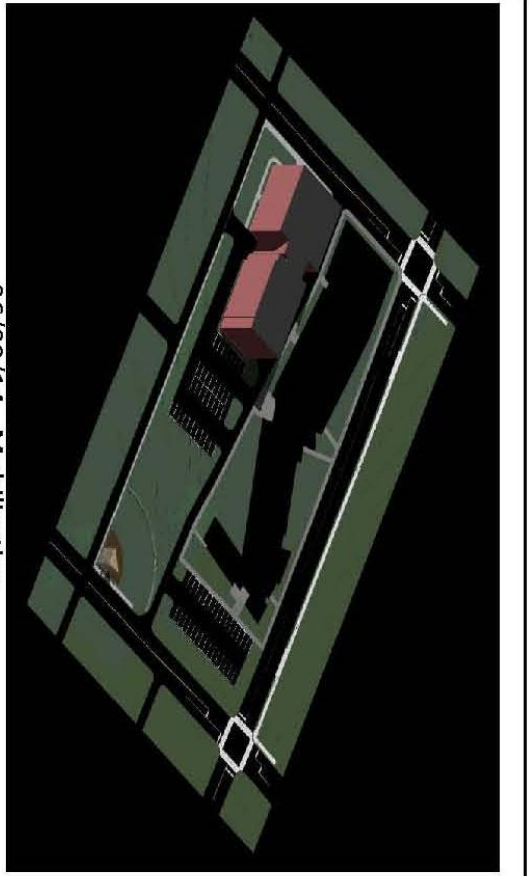

06/09/14 - Mobilization

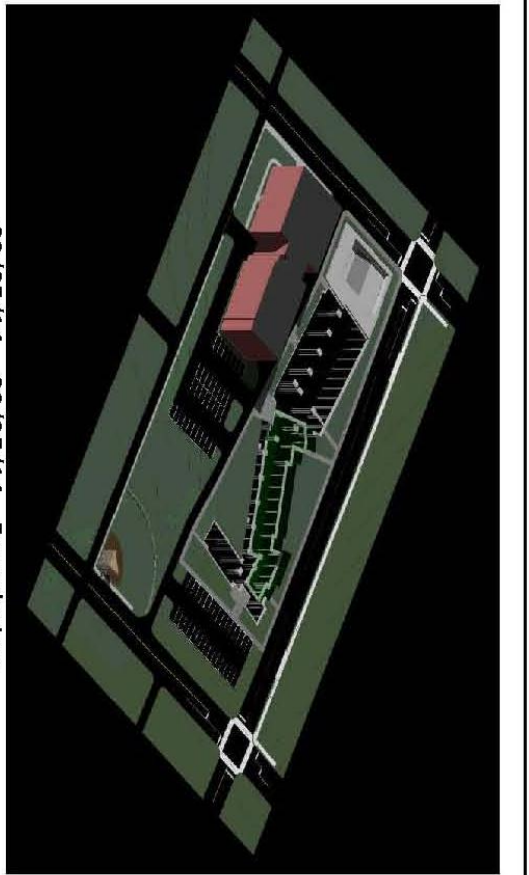

08/05/14 - 08/25/14 - Foundation

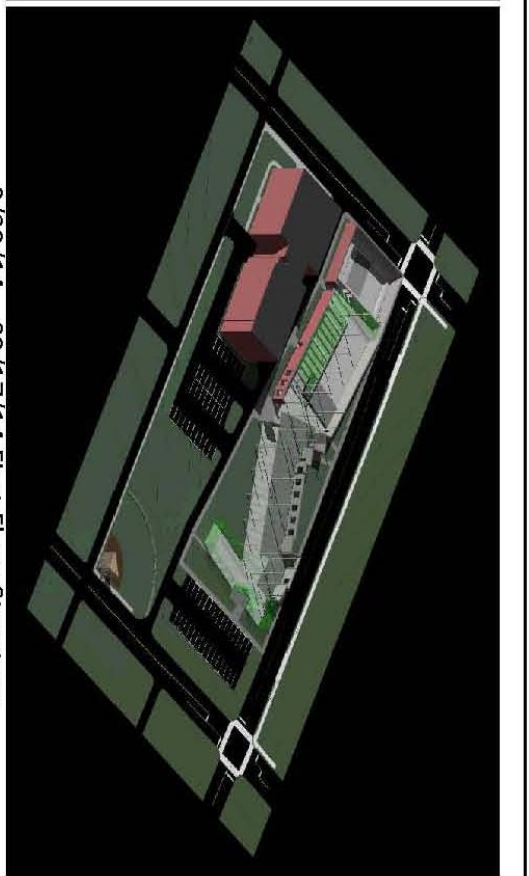

8/29/14 - 09/17/14 First Floor Structure

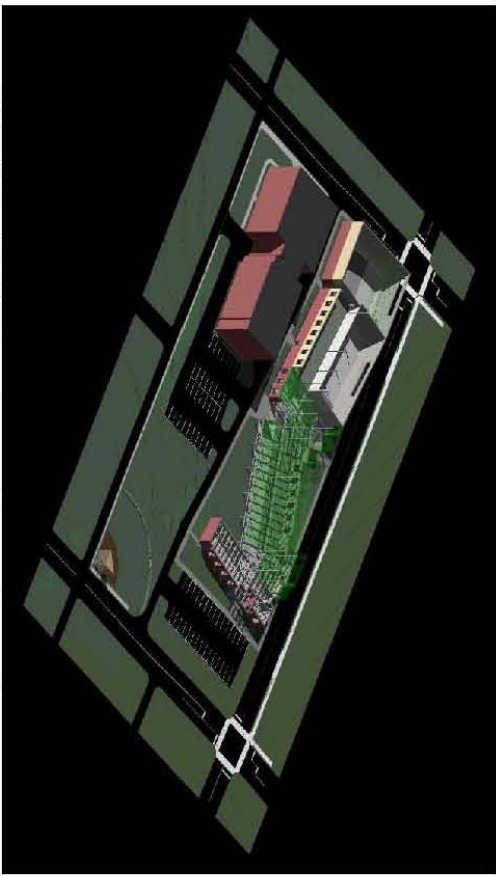

09/17/14 - 10/02/14 - First and Second Floor Structure

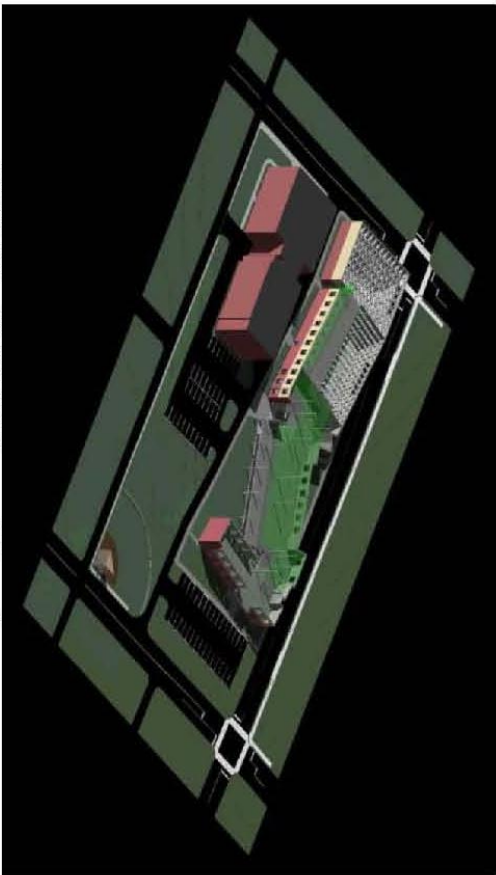

10/02/14 - 10/31/14 Second Floor Structure

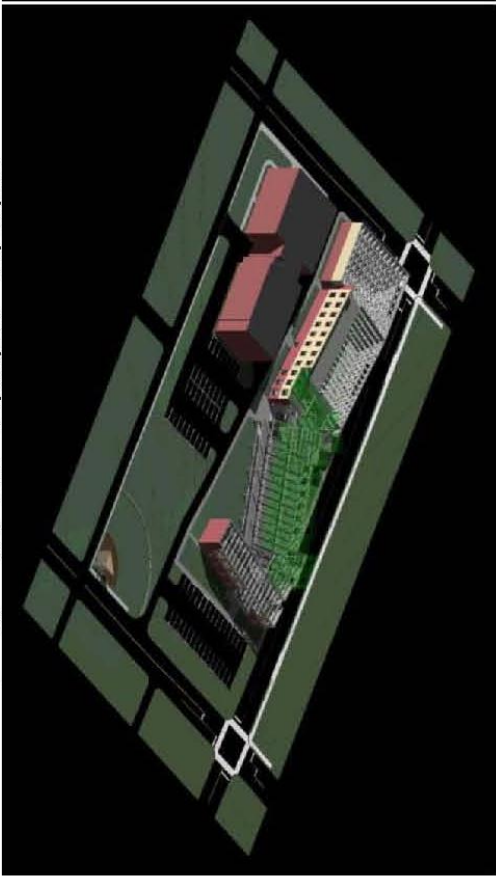

10/31/14 - 11/27/14 - Third Floor Structure

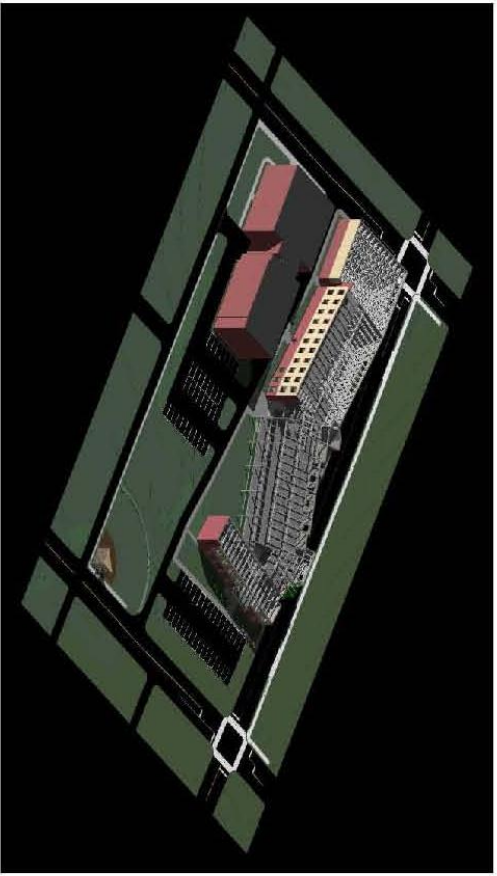

11/27/14 - 1/21/15 Structure Complete

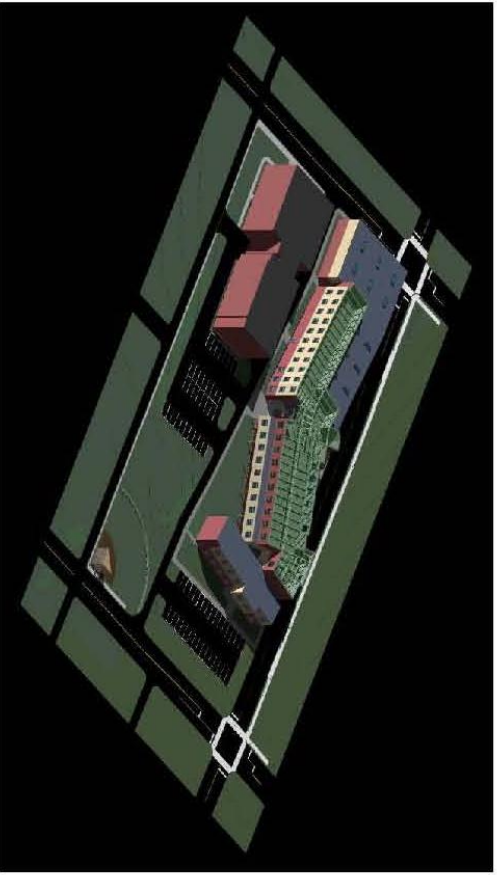

1/21/15 - 2/12/15 Roofing and Glazing

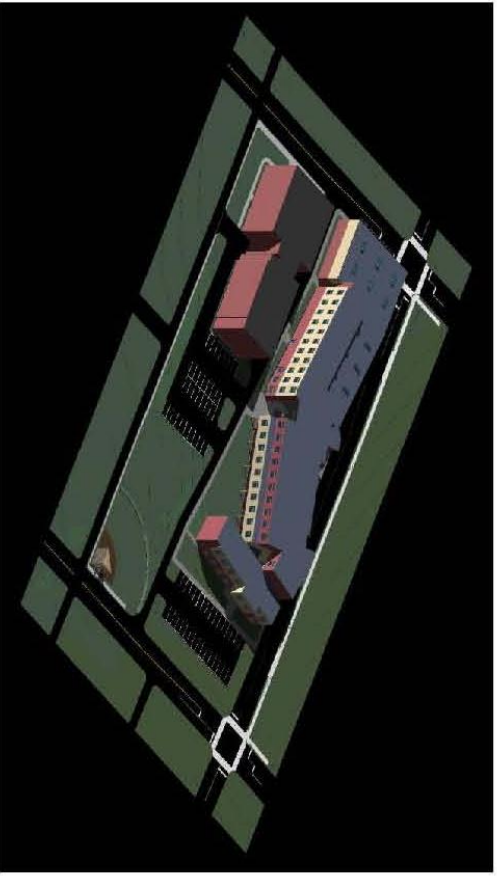

2/12/15 - 4/21/15 - Building Enclosed

SAMPLE LOAD CALCULATIONS

C_s Coefficient Calculation

Spectral Response Acc. (from ASCE 7-05)	Building Data	Story Heights
S _s = 0.25	Total Height: 28 ft	Roof 0 ft
S ₁ = 0.06	Ct value: 0.02	3rd Floor 28 ft
F _a = 2.5	x: 0.75	2nd Floor 14 ft
F _v = 3.5	Imp. Factor: 1.25	Time Period (from ETABS)
T _L = 6	R (N-S)= 4	= 0.289 s
	R (E-W)= 4	

S_{0.5}= 0.417

S_{0.1}= 0.140

T₀= 0.067

T_L= 6

T_s= 0.336

T_a= 0.289

S_a= 0.417

N-S:

R= 4

C_s= 0.1302

C_s= 0.1514

E-W:

R= 4

C_s= 0.1302

C_s= 0.1514

C_s= 0.1302

C_s= 0.1302

EARTHQUAKE LOAD CALCULATIONS

Loads:		Trib Areas:	
Roof dead=	30 psf	Roof=	0 ft ²
Floor dead=	60 psf	Roof Level Floor=	0 ft ²
ICF Walls=	125 lbs/per sf wall area	ICF Wall=	0 ft ²
Curtain Walls=	50 lbs/per sf wall area	Curtain Wall=	0 ft ²
		3rd Floor Roof=	5048 ft ²
		3rd Floor Level Floor=	0 ft ²
		ICF Wall=	1750 ft ²
		Curtain Wall=	364 ft ²
		2nd Floor Roof	0 ft ²
		2nd Floor Level Floor	5048 ft ²
		ICF Wall	3500 ft ²
		Curtain Wall	784 ft ²

Roof Level Load

W= 0.0 kips

3rd Floor Load

W= 388.4 kips

2nd Floor Load

W= 779.6 kips

Total W= 1167.97 kips

Load Distributions:

N-S:
Base Shear= 152.1 kips

E-W:
Base Shear= 152.1 kips

k= 1
C_{VR}= 0.0000
C_{V3}= 0.4991
C_{V2}= 0.5009

N-S:		E-W:	
Roof	0.0 kips	Roof	0.0 kips
3rd Floor	75.9 kips	3rd Floor	75.9 kips
2nd Floor	76.2 kips	2nd Floor	76.2 kips

ETABS MODEL – WEST WING & CENTRAL WING

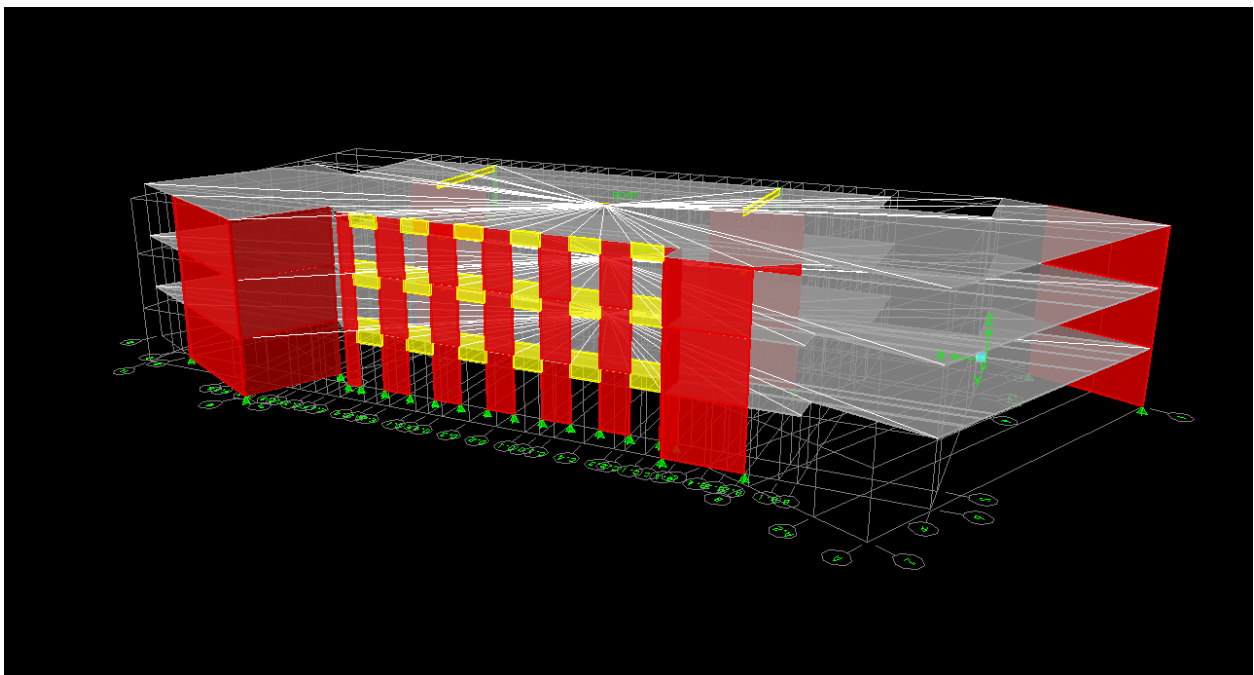
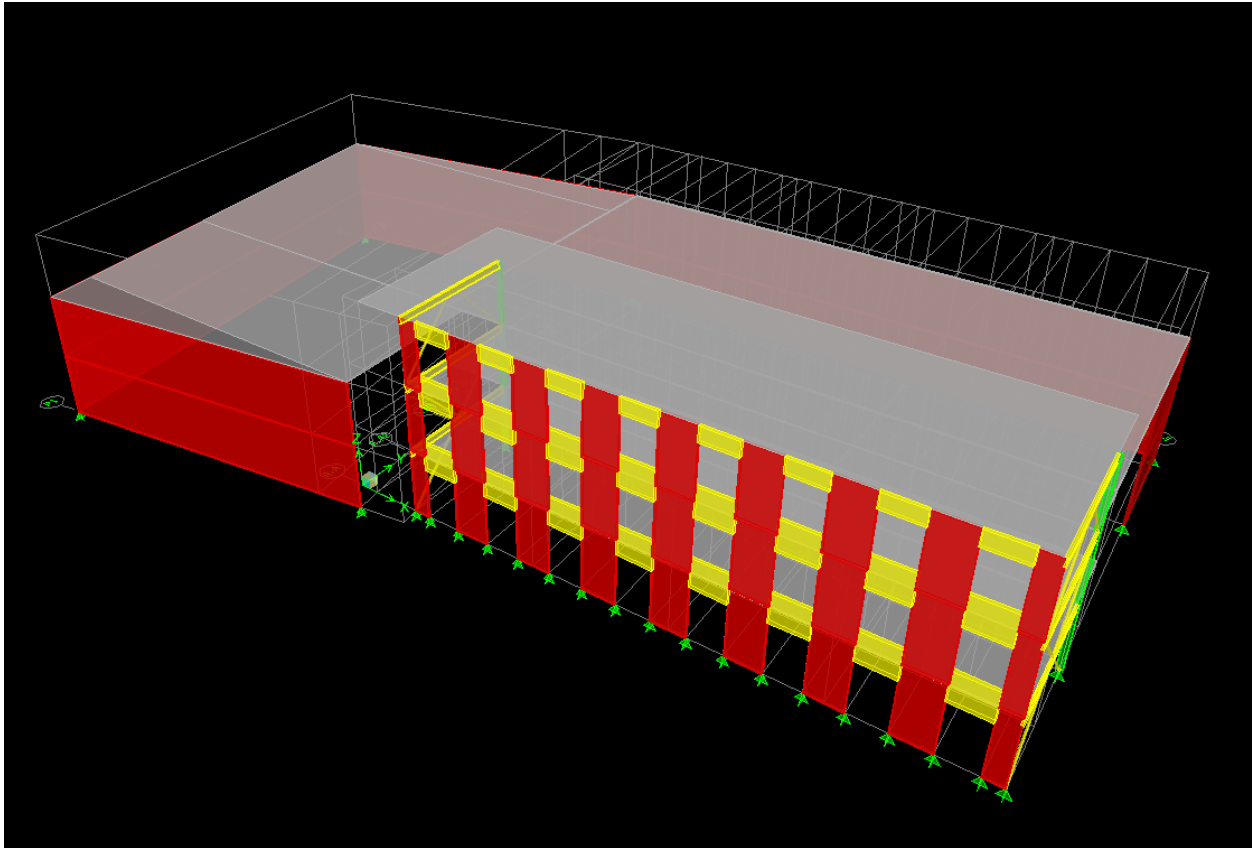

ETABS MODEL – EAST WING & LATERAL FRAME BRACING

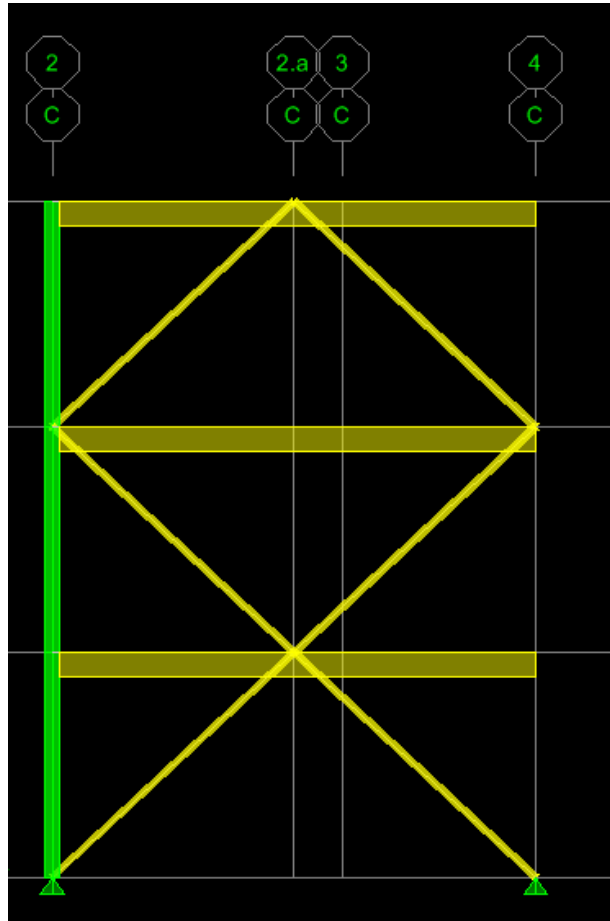
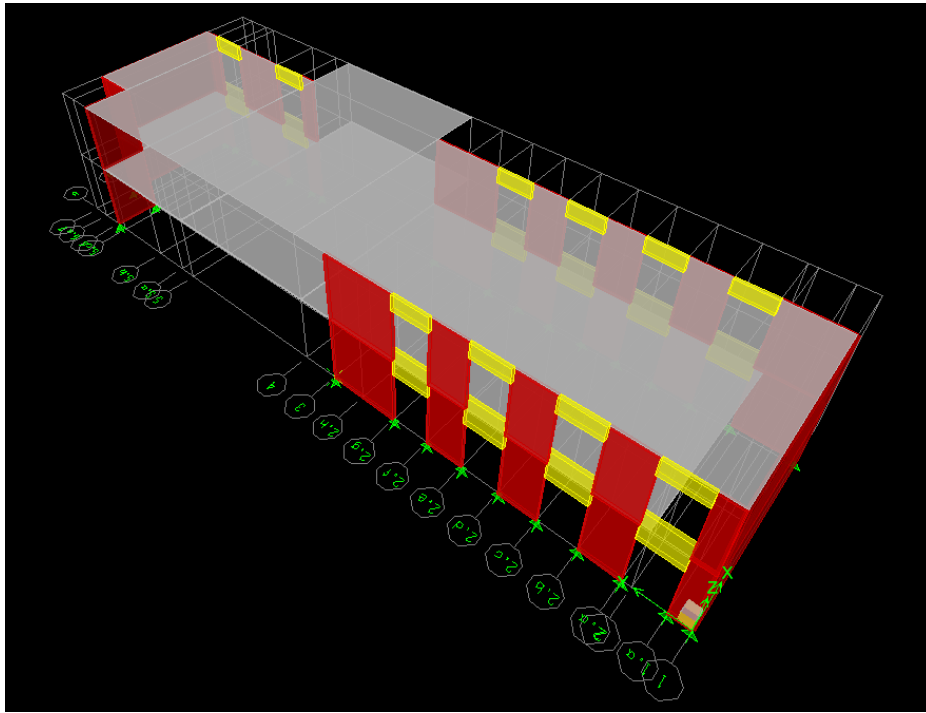

SAMPLE SECOND FLOOR STRUCTURAL FRAMING LAYOUT

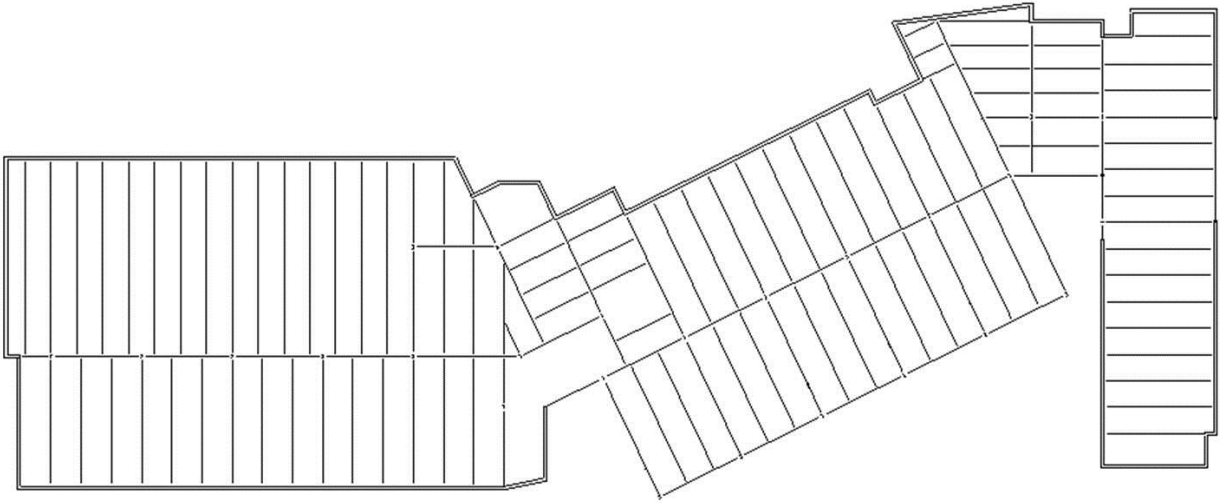

ROOF & BASEMENT MECHANICAL LAYOUT

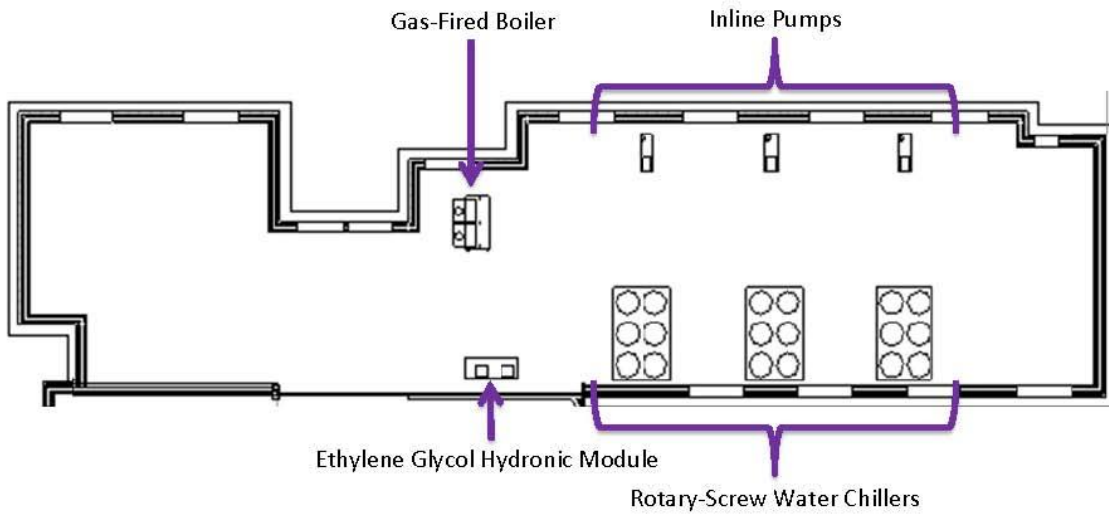
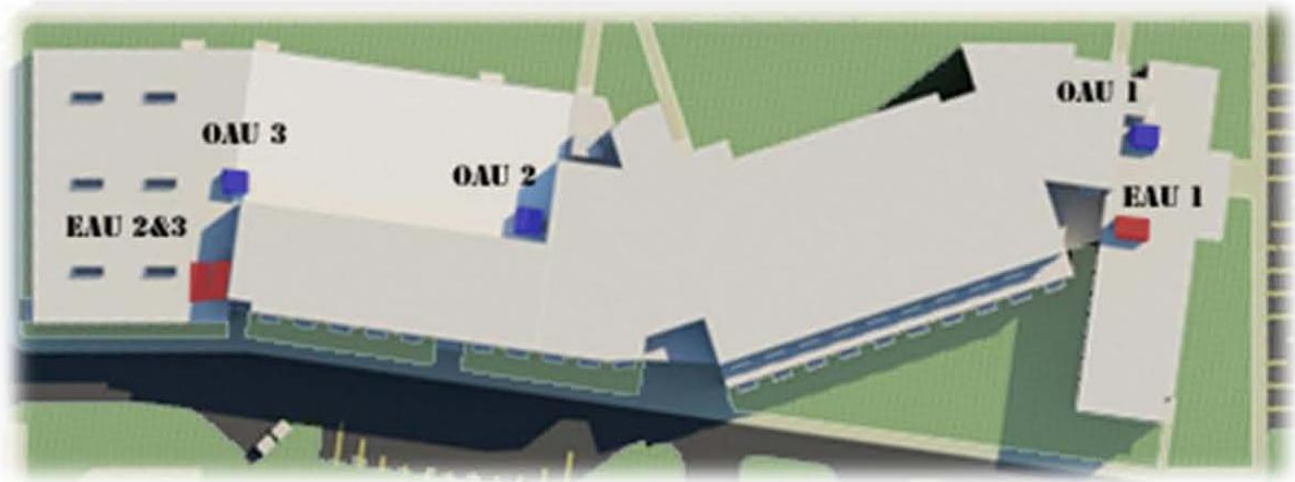

MECHANICAL EQUIPMENT BREAKDOWN

Equipment Breakdown			
Equipment	Description	Capacity	Price
Chiller-1	Rotary-Screw Water Chillers	60 Tons	\$ 55,300.00
Chiller-2	Rotary-Screw Water Chillers	60 Tons	\$ 55,300.00
Chiller-3	Rotary-Screw Water Chillers	60 Tons	\$ 55,300.00
Cooling Tower	Axial Fan, Induced Draft	175 Tons	\$ 27,375.00
Boiler-1	Gas-Fired Boiler	800 MBh	\$ 16,475.00
Boiler-2	Gas-Fired Boiler	350 MBh	\$ 7,725.00
OAU-1	Dedicated Outdoor Air	38,000 CFM	\$ 172,400.00
OAU-2	Dedicated Outdoor Air	27,000 CFM	\$ 163,200.00
OAU-3	Dedicated Outdoor Air	8,000 CFM	\$ 54,400.00
EAU-1	Exhaust Air Unit	34,500 CFM	\$ 12,320.00
EAU-2	Exhaust Air Unit	24,500 CFM	\$ 10,540.00
EAU-3	Exhaust Air Unit	9,000 CFM	\$ 5,600.00
Ethylene-Glycol System	Without Pool	65,000 CFM	\$ 295,000.00
Ethylene-Glycol System	With Pool	8,000 CFM	\$ 355,000.00
Total	Without Pool		\$ 863,210.00
Total	With Pool		\$ 990,935.00

ETHYLENE GLYCOL SCHEMATIC

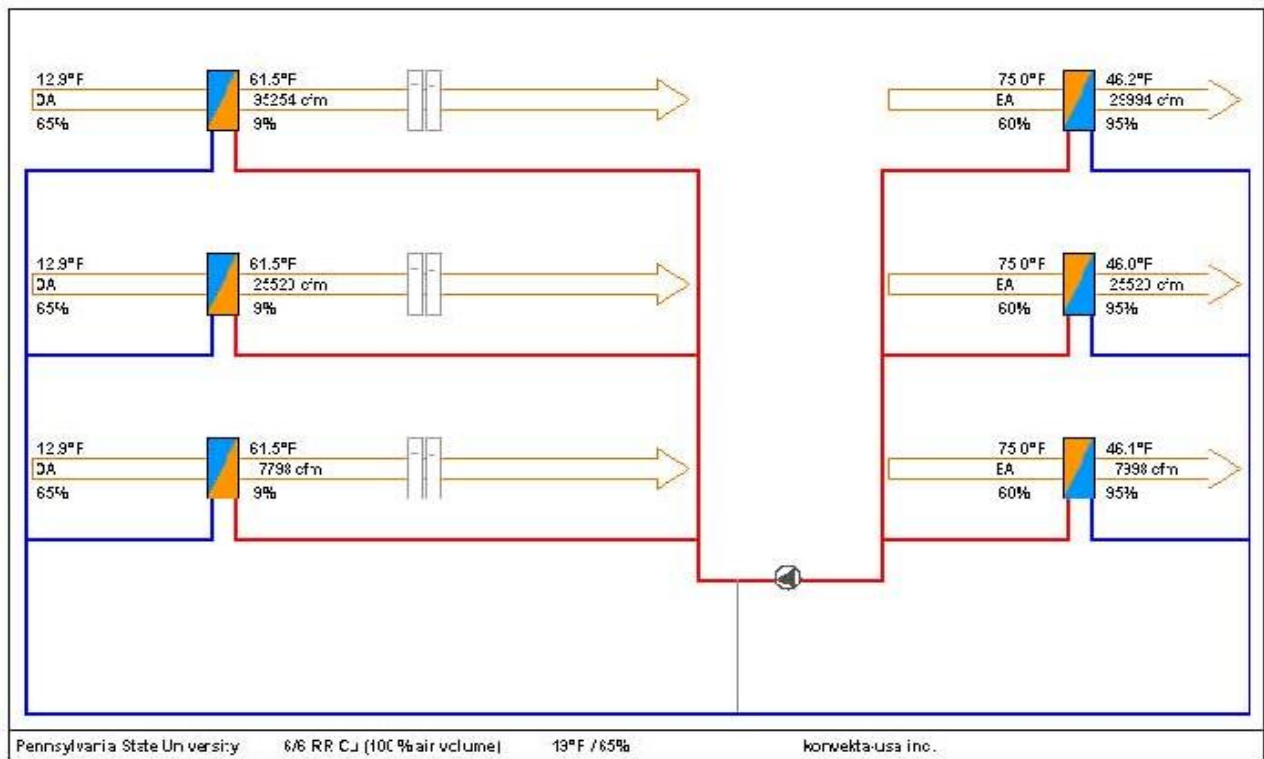
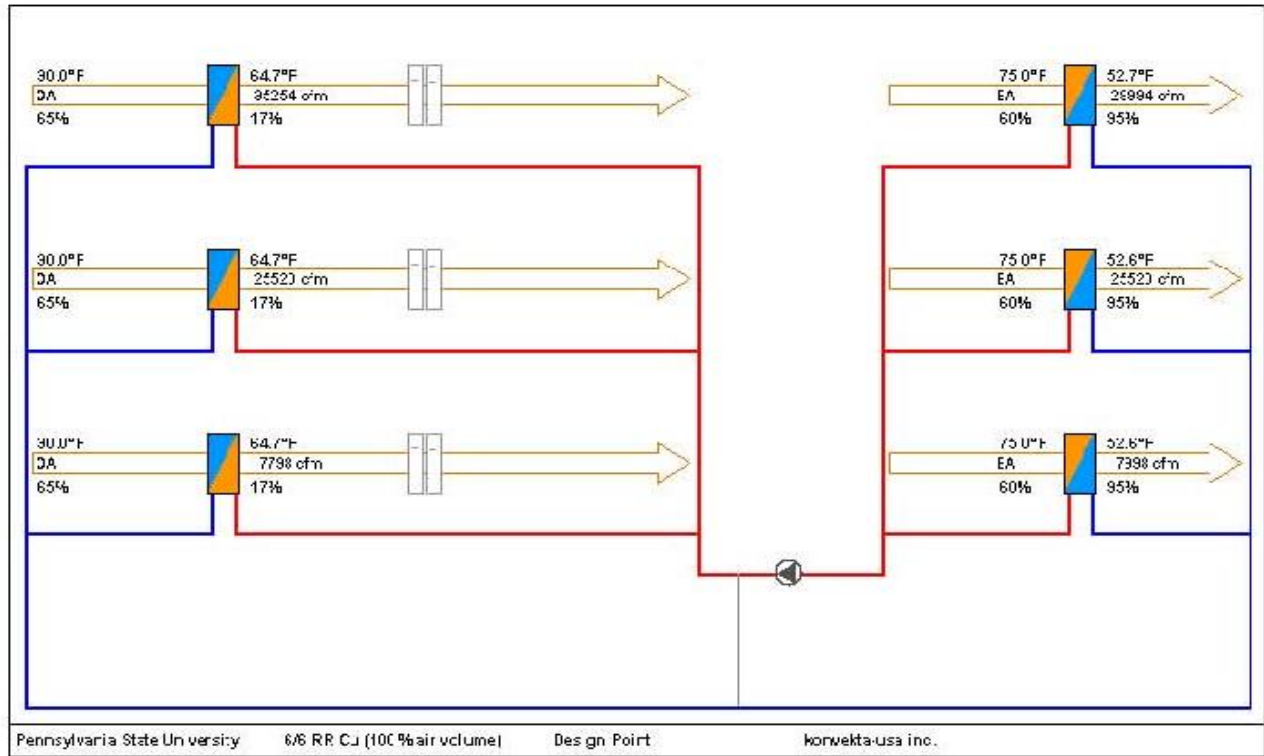

ETHYLENE GLYCOL ENERGY COMPARISONS

Energy/Financial Comparison: Pennsylvania State AEI

OAU-1/2, EAHU-1/2

		Without E Recovery	Konvekta System
SUMMARY			
Winter			
Heating Energy Requirement	kWh/a	856,050	402,000
Effectiveness Heating			0.53
Summer			
Cooling Energy Requirement	kWh/a	194,610	173,410
Effectiveness Cooling/Reheat			0.08
Year			
Heating Energy	kWh/a	856,050	402,000
Cooling Energy	kWh/a	194,610	173,410
Electricity (Δ Fans, Pumps)	kWh/a	0	14,503
Total Energy Consumption	kWh/a	1,050,660	594,913
Effectiveness			43%
Peak Demand			
Cooling	kW	1,525	1,355
	tons	433	385
Heat	kW	1,340	535
	MBTU/h	4,572	1,825

Energy/Financial Comparison: Pennsylvania State AEI

OAU-1/2/3, EAHU-1/2/3

		Without E Recovery	Konvekta System
SUMMARY			
Winter			
Heating Energy Requirement	kWh/a	965,900	407,500
Effectiveness Heating			0.58
Summer			
Cooling Energy Requirement	kWh/a	219,660	201,460
Effectiveness Cooling/Reheat			0.09
Year			
Heating Energy	kWh/a	965,900	407,500
Cooling Energy	kWh/a	219,660	201,460
Electricity (Δ Fans, Pumps)	kWh/a	0	11,514
Total Energy Consumption	kWh/a	1,185,560	624,474
Effectiveness			47%
Peak Demand			
Cooling	kW	1,722	1,522
	tons	489	432
Heat	kW	1,512	411
	MBTU/h	5,159	1,402

UTILITY COST ANALYSIS

Project Information

Location: Reading, PA
 Project Name: Elementary School
 User:
 Company:
 Comments:

Study Life: 20 years
 Cost of Capital: 10 %
 Alternative 1: Reading Elementary School

Economic Comparison of Alternatives

Yearly Savings (\$)	First Cost Difference (\$)	Cumulative Cash Flow Difference (\$)	Simple Payback (yrs.)	Net Present Value (\$)	Life Cycle Payback (yrs.)	Internal Rate of Return (%)	Life Cycle Cost
---------------------	----------------------------	--------------------------------------	-----------------------	------------------------	---------------------------	-----------------------------	-----------------

Annual Operating Costs

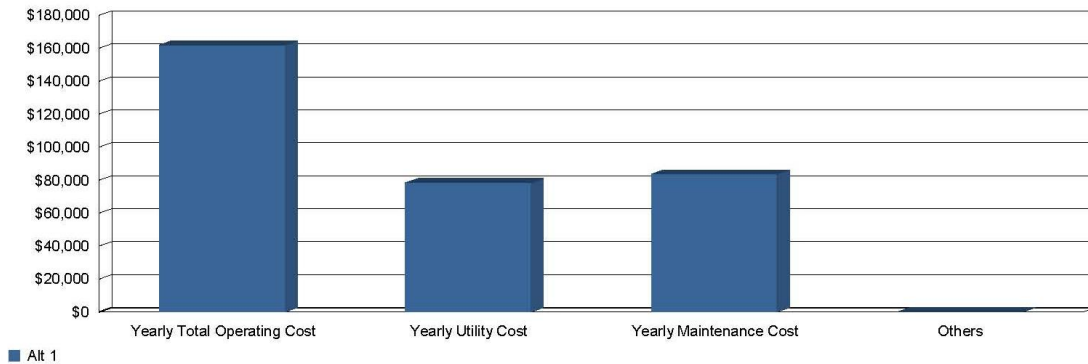

Yearly Total Operating Cost (\$)	Yearly Utility Cost (\$)	Yearly Maintenance Cost (\$)	Plant kWh/ton-hr
----------------------------------	--------------------------	------------------------------	------------------

Monthly Utility Costs

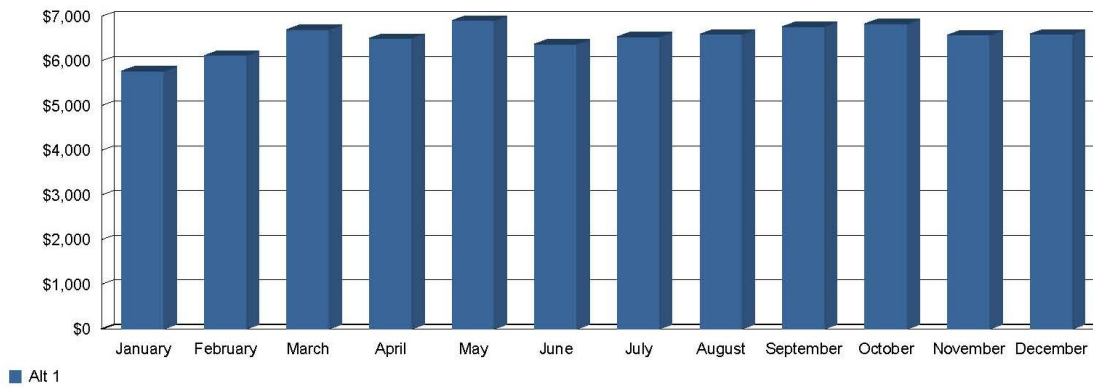

Project Name: Elementary School
 Dataset Name: READING ELEM EQ.TRC

TRACE 700 6.2.8
 calculated at 01:24 PM on 12/13/2012

LOBBY FIXTURE CUTSHEET

CYLINDRO II COLOR LED WITH OPAL ACRYLIC DIFFUSER



TYPE:

PROJECT:

ORDER NUMBER:

Select	Select	Select	Select	Select
Model#	Finish	LEDs	Voltage	Option
6703-3 ft.	S-Silver	R-red	1-120V	SLRD
6704-4 ft.	W-White	B-blue	2-277V	BDIM-RGB
6705-5 ft.	K-Black	CW-Cool White		BDIM-W
		WW-Warm White		BDMOD
		SQ-RGB sequencer		

Example:

6705	W	SQ	1	BDMOD
------	---	----	---	-------

Traxon Light Drive* (enter quantity)

Qty	BTRAXW (white)	Qty	BTRAXB (black)
-----	----------------	-----	----------------

CANOPY

- Mounts to all standard JBoxes
- Specify C2RB for remote ballast compartment in accessible ceiling or through access panel.

CONSTRUCTION

- Extruded aluminum outer housing with white frosted acrylic diffuser. 6' adjustable power cord and AC cables with push button grippers supplied standard. (Specify XP for additional length.)

LED

- Electronic drivers, DMX and dimmer interface housed in canopy or remote gear box (C2RB), for easy access.
- Color sequencer option features potentiometer speed control; or fixture may be ordered with dimmer or DMX interface. (See second page for details.)
- All LED components are OSRAM Sylvania.
- U.L. Listed for dry locations.

- 6703-3 ft.
- 6704-4 ft.
- 6705-5 ft.

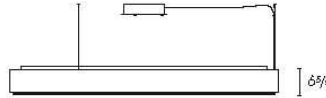

DIMENSIONS

Model	ID	OD
6703	34.875"	40.625"
6704	46.9"	52.625"
6705	58.9"	64.625"

DELRAY
LIGHTING
INCORPORATED

CYLINDRO II

MULTI-PURPOSE ROOM CUTSHEET

LUMINIS

PR2220/PR2221
PRISMA NOVA 22 - HID/CFL

TYPE: _____ QUANTITY: _____ PROJECT: _____

CATALOG NUMBER:

FIXTURE WATTAGE VOLTAGE FINISH OPTION OPTION OPTION OPTION

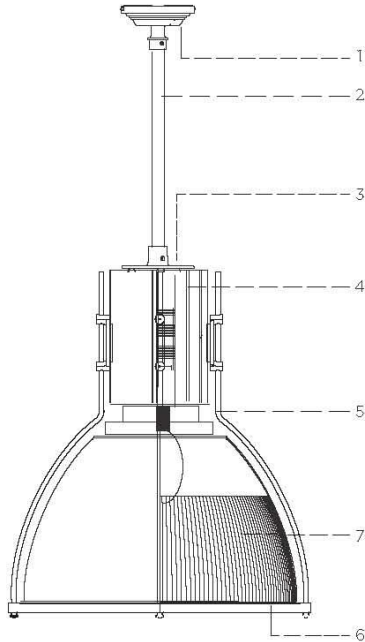

Ceiling pendant luminaire with a choice of clear acrylic prismatic diffuser or an anodized aluminum reflector with two part inner surface treatment. Upper etched surface combined with multi faceted specular lower part. Optional attachments and accessories are available to customize and adapt each luminaire to particular design requirements.

- 1- Standard heavy duty 45° hang straight swivel, with 5" Dia. (127) canopy and universal mounting plate.
- 2- 7/8" Dia. (22) X36" Lg. (900) suspension stem. Precut factory stems are available on request. (Specify STM with desired length)
- 3- Cast aluminum removable top cover for quick maintenance.
- 4- Extruded aluminum ballast housing module with a fine linear stria pattern.
- 5- Set of four side struts secured in position with a cast aluminum holder.
- 6- Lens holder ring. (See options for clear lens.)
- 7- **PR2220:** Clear acrylic prismatic diffuser.
PR2221: Aluminum reflector.
Inner surface: multi faceted specular anodized.
Exterior surface: Satin anodized natural aluminum.
Alternate exterior finish (Option RP8)

PR2220
PR2221



MATERIALS

Prisma is composed of an extruded aluminum ballast housing designed to optimize electrical components functionality. Prisma is available with a choice of two interchangeable reflectors.

- An aluminum reflector designed to optimize light source performance and uniformity.
- A clear prismatic diffuser with a linear peripheral pattern providing general upward illumination with efficient down lighting.

ELECTRICAL

Metal Halide electronic ballast 120/277V smart volt, or 347V (50-60HZ) with a minimum starting temperature of -30°C/-20°F including EOL protection. HPF/PS Magnetic ballast for wattages over 150W. Sockets are medium or mogul base pulse rated 4KV porcelain body with nickel plated screw shell and center contact rated 600V. Supplied with 200°C leads. Compact Fluorescent electronic ballast 120/277V smart volt, or 347V (50-60HZ) with EOL protection. Minimum starting temperature of 0°F/-18°C. Sockets are thermoplastic body rated for 75W-600V. Supplied with 105°C leads.

FINISH

Five stage preparation process including preheating of cast aluminum parts for air extraction, and environmentally friendly alloy sealant. Polyester powder coating is applied through an electrostatic process and oven cured for long lasting finishes.

MOUNTING

Max. weight: 18.5 Lbs. (8.3)
Installation: Mounts over a standard 4" (100) Octagonal electrical box with 3 1/2" (89) C/C mounting holes.

CERTIFICATION

Tested to UL1598 standards and CSA 22.2 #250. usULc listed damp location.
CE certification on request.

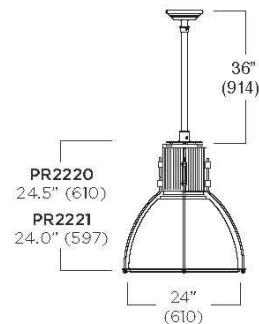

2 Rev.#4

POOL FIXTURE CUTSHEET

Lighting the Ceiling Large Ensconce, Integral

Metal Halide

Ensconce[®] Style 406

Base Unit 1:10 Scale

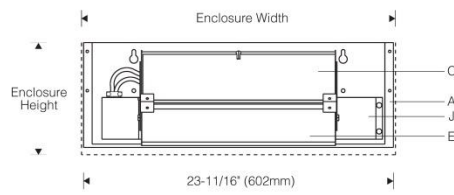
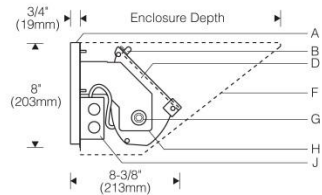

Enclosures 1:16 scale

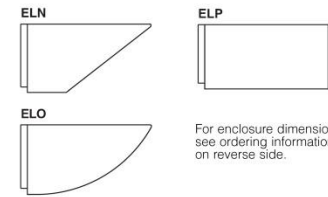

For enclosure dimensions, see ordering information on reverse side.

Mounting Plate

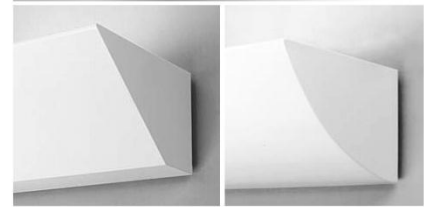
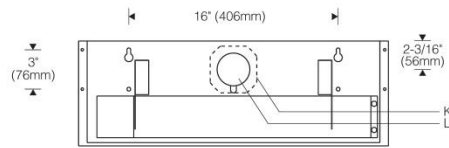

Specifications

- | | | | |
|--|---|--|---|
| A Aluminum yoke/mounting plate (forms reveal at wall) | D Stamped specular aluminum end plates | F Sconce enclosure (ordered separately) | J Integral ballast with wiring compartment |
| B Lens retainer clip | E Specular extruded aluminum reflector | G Beveled spring washers | K Outlet box (by others) |
| C Lay-in micro-prismatic tempered glass lens | | H Yoke arms | L Removable splice access cap |

Finish:

Bright clear anodized aluminum reflector and end plates; black mounting plate. (Enclosure finish specified separately.) Painted surfaces - 6 stage pretreatment and electrostatically applied thermoset powder coat for stable, long lasting and corrosion resistant finish.

Reflector and internal end plates - extruded high purity aluminum with clear anodized specular finish. All luminaire hardware - stainless steel.

Mounting:

Mounting plate fastens to suitable structure over recessed outlet box, and supports enclosure (ordered separately).

Standard:

UL listed or CSA certified for damp locations. (Style 454 painted model with gasketed lens recommended for damp locations; see Outdoor Section.) Suitable for upright orientation only.

Electrical:

Use 90°C wire for supply connections. Integral encapsulated constant wattage autotransformer (CWA) ballast.

Mogul lampholder is pulse rated for use with either horizontal or universal position reduced envelope pulse start lamps. End-of-lamp aligner ensures consistent optical performance. For complete ballast specifications, see Accessories Section.

Enclosure (ordered separately):

Seam welded, ground smooth cold rolled steel. Edges are rolled to eliminate "oil canning." Attaches to base unit forming a reveal at the wall to prevent light leaks and delineate the form. Thermoset powder coat finish.

Features

- Choice of crisp geometric enclosures or design your own
- Lamp support on mogul base lamps ensures arc tube is in optical center
- Integral encapsulated CWA ballast for quiet operation
- Adjustable - beveled spring washers secure aiming
- Extruded reflector - will not deform during maintenance



Performance

Two parabolic reflector sections drive light across the ceiling from one edge. An elliptical section shields the lamp from normal viewing angles and redirects its light to a parabola. Glare is minimized and asymmetry of the beam is maximized resulting in high beam efficiency and superior surface uniformity.

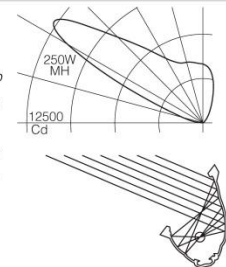

For complete photometrics, visit www.elliptipar.com

elliptipar

CLASSROOM FIXTURE CUTSHEET

soleil PENDANT MOUNT

ÉCLAIRAGE 1.800.263.AXIS
axis [T] 514.948.6272
LIGHTING [F] 514.948.6271
 www.axislighting.com

● **PROJECT INFORMATION**

Project:

Type:

Notes:

● **DIMENSIONS**

SECTION VIEWS

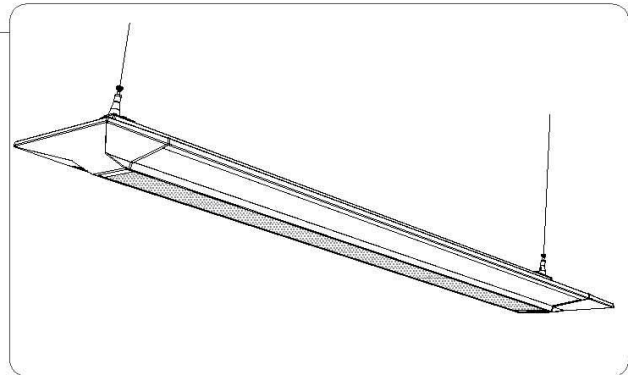
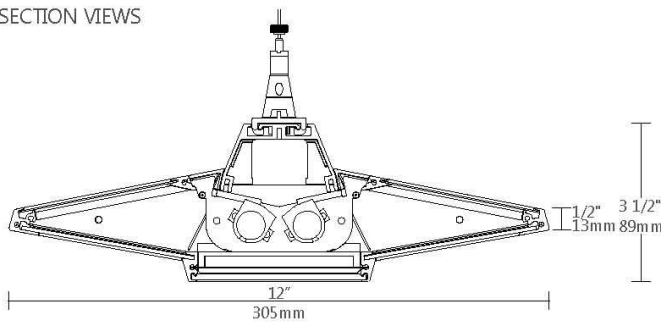

● **ORDERING CODE**

1	2	3	4	5	6	7	8	9	10	11	12	13	14	15
---	---	---	---	---	---	---	---	---	----	----	----	----	----	----

● **PRODUCT SPECIFICATIONS**

1 PRODUCT ID	2 OPTICS	3 LIGHT DISTRIBUTION	4 LENGTH/FT	5 LAMP	6 LAMP CONFIGURATION
SOL pendant	VL vl optic	30/70 30% up 70% dn 20/80 20% up 80% dn 0/100 0% up 100% dn <small>Approximate light distribution</small>	4 4' 8 8' 12 12' S# System Run	T5 T5 T5HO T5HO T8 T8	1 1 lamp 2 2 lamps 3 3 lamps ⁽¹⁾ <small>(1) Not available for T8</small>

7 FINISH	8 VOLTAGE	9 BALLAST	10 CIRCUITS	11 MOUNTING/SUSPENSION
AP aluminum paint W white C custom	120 120V 277 277V 347 347V ⁽²⁾ UNV universal <small>(2) Consult factory</small>	D dimming E instant start ERS rapid start T step dimming ⁽³⁾ <small>Use ballast guide for ballast specification (3) T5HO, only available for 2x4' lamp configuration</small>	1 1 regular 2 2 regular 2A/B 2 alternating +E# emergency section +NL# night light section +GTD# generator transfer device	CA# drywall+cable length CT# t-bar+cable length SA# drywall+stem length >48"

12 BATTERY	13 OTHER	14 IC CONTROLS	15 CUSTOM
B# battery pack 4' sections	F fuse	DS# daylight sensor OS# occupancy sensor DS+OS# daylight+occupancy sensor DOS# daylight&occupancy sensor <small>See integrated controls guide for further details</small>	C custom <small>Please specify</small>

Ballast, Battery Pack and Integrated Control Details and Custom Description:

Lighting/Electrical

This page reserved for one more lighting/electrical sheet